

PCK43304W

433MHz PentaCODE® Transmitter with 4 External Inputs

Features

- Four external inputs (voltage free)
- Compatible with all PCR Penta series receivers
- 12 to 24 Volts AC/DC supply or 12 Volt battery
- Frequency hopping between 433.100 to 434.700 MHz
- Easy coding with 12-way dipswitch or encrypted coding



Applications

Wireless Push Button, Industrial Controls, Duress button, Security, PLC controlled transmitter or to reduce the need to run control wires over a long distance.

Description

This easy-to-install transmitter combines 4 inputs, long range, frequency hopping and different transmission modes into a single small device. This transmitter is a fixed high power transmitter compatible with the Penta (PCR series) receivers.



With the frequency hopping, the transmitter allows multiple systems to be used in one area with no interference. The transmitter modes are user selectable and adjustable timing is set with an on board trimpot. LED indicates an input is activated.

Installation is easy with pluggable terminal blocks for the supply and inputs. The transmitter comes with a micro antenna that can give an operating range of up to 500 metres.

Technical Data

Supply Voltage	12 to 24 Volts AC or DC
Standby Current	6uA standby at 12 Volts DC. (Suitable for battery operation)
Current Consumption	27mA when transmitting
Frequency Band	433.100 to 434.700 MHz
Operating Range	Up to 500 metres
Number of Inputs	4 dry contacts, optically isolated
Connections	Screw type terminal block. See block diagram
Dimensions	90mm x 50mm x 25mm
Weight	70 grams
Useable Receivers	All 433MHz Penta series

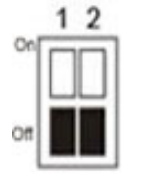
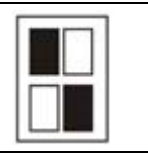
Transmitter Modes

	<p><i>Off Delay 2 – 62 seconds</i> Transmitter will transmit a 1.5 second transmission burst and then stop for the "off delay" time selected. The "off delay" time is user selectable between 2 to 62 seconds by adjusting trimpot on the transmitter board. If the inputs change during the "off delay" period, the new code will be transmitted immediately.</p>
	<p><i>Reserved</i></p>
	<p><i>Continuous Transmission*</i> Transmitter will transmit continuously, if at least one input is activated and supply is connected. A transmission limit of five minutes is used to comply with local radio regulations.</p>
	<p><i>1.5 – 10 seconds one burst transmission</i> Transmitter will transmit one burst and then go to standby or sleep mode. Adjusting the trimpot will vary the burst length. When the input is changed and supply is connected, transmitter will transmit one new burst of the new code.</p>

(Grey illustrates the position of the DIP switches)

Keeping the receiver ON indefinitely

Set the transmitter to transmit every 10 sec while the input is activated (Off-delay on the transmitter) and set the delay on the receiver to more than 30 sec (more than x3). When the transmitter stops transmitting (Input is deactivated) the receiver will wait for 30 sec before turning Off. Every 10sec pulse from the transmitter will keep extending the 30sec delay on the receiver so the relay stays ON.

The times are just examples and can be adjusted. The longer the delay on the receiver, the better it is. It means the receiver should miss multiple signals before turning OFF. This will also mean that when the transmitter stops, the receiver will wait for it's delay time before turning off.

Make sure to choose the receiver which has the OFF Delay mode.

Block Diagram

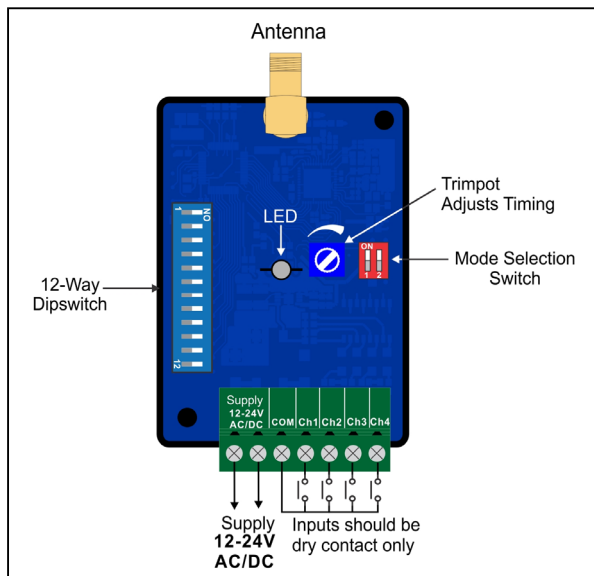

Inputs of the transmitter should be voltage free contact closure only.

PentaCODE® Programming Instructions

12- Way Dip Switch Coding

1. Set a random code on the receiver dip switch by flicking the dip switches "On" or "Off".
(DO NOT USE THE DEFAULT FACTORY SETTING FOR THE 12-WAY DIP SWITCH AS THIS IS A COMMON CODE)
2. Open the cover of the PentaCODE® transmitter.
3. Match the 12-way dip switch to the receivers 12-way dip switch.
4. Activate channel 1 on the transmitter and the receiver output should activate. This is indicated by the receiver LED.

To program the same PentaCODE® transmitter channels 2, 3 or 4 to another receiver change dip switch 11 and 12 in the 2nd, 3rd and 4th receivers. For example:

	Receivers Dip Switch 11	Receiver Dip Switch 12
Receiver 1	Off	Off
Receiver 2	On	Off
Receiver 3	Off	On
Receiver 4	On	On

Dip switches 1 to 10 should all be the same in the transmitter and the receivers.

Encrypted Coding - (All 12-Way Dip Switches must be "Off")

Coding the PentaCODE® transmitter and receivers can be done in 3 different ways.

1. Receiver to a transmitter
 2. Transmitter to a Receiver
 3. Transmitter to another transmitter
- Receiver to a transmitter
1. Press and hold the program button 1 on the receiver.
 2. Activate channel 1 of the transmitter for 2 seconds, receiver LED will flash Green
 3. Deactivate channel 1 of the transmitter then release the receiver program button.
 4. The LED on the PentaCODE® transmitter will flash to confirm the coding has been successful.
- Transmitter to a Receiver / transmitter to another transmitter
- Set one of the transmitter or receiver to broadcast its code. The broadcaster's code will be programmed to the other units.
- To broadcast the transmitters code, make sure all 12 dip switches are "off". Then activate channel 1 and flick dip switch 12 "on" and then "off". This is confirmed by the LED being "on" for 10 seconds. You can release channel 1.
 - To broadcast the receivers code, make sure all 12 dip switches are "off" and then flick dip switch 12 "on" and then "off". This is confirmed by the green LED being on for 10 seconds.
- While broadcasting the code, activate channel 1 on a different transmitter or receiver for 1 second and then release the input. The LED will flash twice to confirm successful programming.

Broadcasting will be latched on for 10 seconds or stop if any dipswitch is turned on.

Deleting Receivers Memory

Short the CC pin on the receiver for 10 seconds. **This will delete all the transmitters from the receiver's memory.**