

# iS300 Solar Kit

24 Volt motor, Suitable for gates up to 3 metres and 300kg

## SOLAR SWING GATE OPENERS



- ) Uses Elsema's MC card with Eclipse® operating system
- ) Ultra quiet operation yet powerful
- ) Die-cast Aluminium motor cover for great durability
- ) Bluetooth Smart built-in
- ) Real-time battery charging data
- ) Mechanical stopper built in the motor for added protection. No stoppers required on your driveway
- ) Waterproof cover design
- ) Soft start and soft stop
- ) Easy installation



Die-cast aluminum cover. Maximum protection against environment



Easy manual release located on the top side of the motor



Strong and reliable worm shaft with  $\varnothing$  18mm spherical section

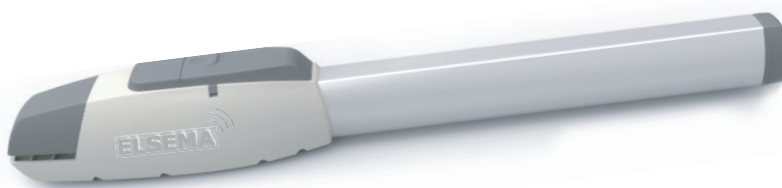

**24 VOLTS HEAVY DUTY GEAR MOTOR**

Search for VictronConnect in App store

### TECHNICAL DATA

Motor voltage	24 Volts DC
Max gate weight	300kg
Max gate length	3 metres
Peak thrust	3000N
Operation stroke	350mm
Typical gate opening time	10-15sec
Duty cycle	20%
Operating temperature	-20°C~50°C

## Typical installation

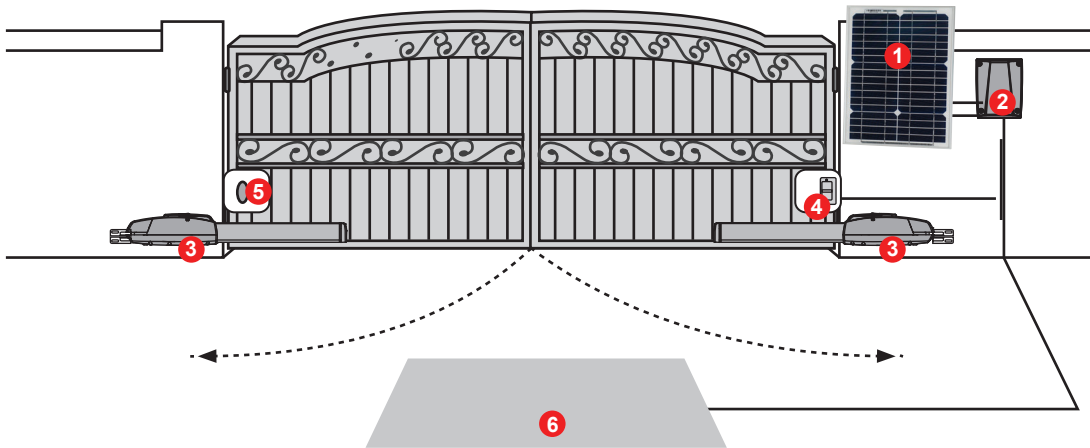

- |   |                            |
|---|----------------------------|
| 1 | Solar Panel                |
| 2 | Intelligent control box    |
| 3 | iS300 motor                |
| 4 | PE1500 photo electric beam |
| 5 | Reflector for PE1500       |
| 6 | Vehicle detector           |

## Kit contents



Control card, Solar panel, Battery & Regulator with MPPT



iS300D dual swing motors with built-in stopper



3 x Keyring remotes with frequency hopping



Long range reflector type photo electric beam

## Dimensions

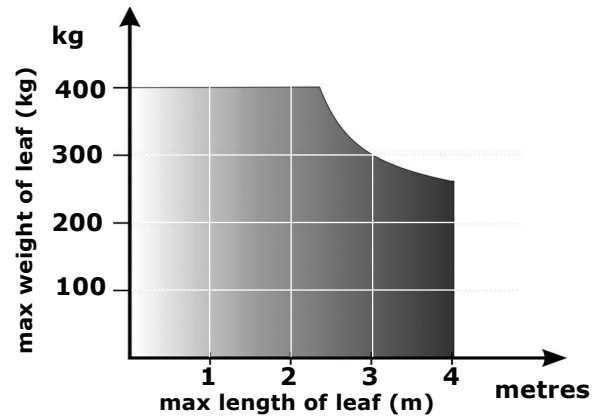
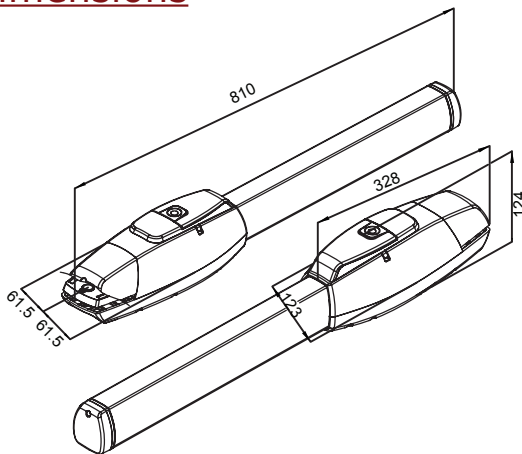

## Ordering Code

PART NUMBERS	DESCRIPTION
iS300DSolar	Dual swing motor kit
iS300Solar	Single swing motor kit



Single 24V, 40Watt Solar panel included in the kit