

GLR270812R, GLR270824R

8-Channel 27MHz Gigalink™ Receiver with Relay Outputs

Features

- Wide supply connection – 11.0 - 14.0 Volts AC/DC for GLR270812R or 21.0 - 28.0 Volts AC/DC for GLR270824R
- Highly sensitive receiver input stage. When used with GLT27... transmitters an operating range of 350 metres (980 ft) is possible.
- Eight relay outputs. All outputs can be operated simultaneously.
- Crystal controlled for high stability and performance.
- Uses micro-controller technology that can be re-programmed to suit unique applications.
- Momentary, flip-flop and latching output modes is user selectable.

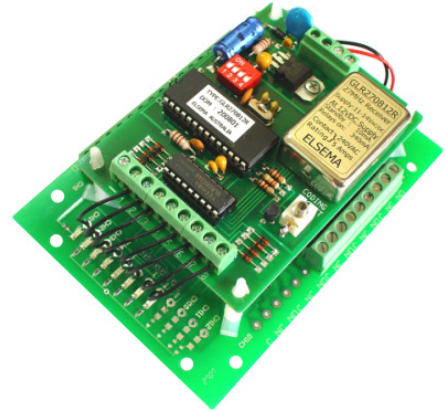

Applications

- Automatic gates.
- Security systems.
- Timer controlled outputs.
- Simple on/off functions.

Description

The GIGALINK™, GLR270812R, GLR270824R is the **most advanced Remote Control technology** available in the world today. GIGALINK™ is an invention that has revolutionised the entire Remote Control technology including Elsema's earlier version of FMT- ... and FMR- ... series.

The GLR2708 state-of-the-art invention brings a new dimension in the world of Remote Control technology in domestic, **commercial and industrial** applications.

The innovative microcontroller technology replaces the traditional dip switch coding which **eliminates** any possible **code grabbing**. Special features such as over four billion code combinations and ability to program any number of transmitters to a receiver adds up to the most advanced and secure Remote Control available.

Different Modes for each Output

Modes are user selectable from the 4-way dip switch, shown below.
 (Dipswitch 4 is reserved for specific customer mode. Normally not used.)

DIP Switch Mode Settings	
The output relay will respond in the following manner when receiving the correct signal from a transmitter	
	"All Momentary": Relay on, only while correct signal is received
	"All Flip-Flop": Outputs alternate at every correct incoming signal
	"Momentary & Flip-Flop": Outputs 1-4 are momentary & 5-8 are flip-flop
	"Latching on": Outputs will be on until supply to receiver is momentarily interrupted
	"Momentary & Flip-Flop": Outputs 1-6 are momentary & 7-8 are flip-flop
	"Momentary & Flip-Flop": Outputs 1-2 are momentary & 3-8 are flip-flop
	"Momentary & Flip-Flop": Outputs 1-3 are momentary & 4-8 are flip-flop
	"Latching on": Output 1 is latching & 2-8 are momentary

*** Dipswitch 4 is reserved**

AC/DC Supply and Antenna

AC/DC power supply and antenna is connected to the 3-way terminal block. The shield of the antenna coaxial cable should be connected to the minus (-) terminal block.

Do not connect the AC/DC supply to the 2.5-mm coding socket since connection may damage the microcontroller.

Channels

The eight channels are relay outputs using the ULN2803 Integrated Circuit. This IC is inserted to a socket that enables the user to easily change the output stage in case of a damaged output. The ULN2803 IC is available from Elsema.

Simultaneous channel operation is possible with the same transmitter.

Code Programming

The microcontroller built-in code programming system automatically selects the programming mode that provides flexibility in programming each receiver channel to different transmitter channels. In programming mode the receiver sends a random code to program the transmitter channel(s). This is known as reverse programming.

Momentary joining the two CC pins on the receiver board sets all eight channels to a random code. To program the receiver to the transmitter channel(s) follow the steps outlined in the receiver instructions.

Applications

The GLR270812R, GLR270824R receiver's eight relay outputs can be set to eight different modes which allows it to be used in many diverse applications such as security, industrial machine monitoring, crane control, level monitoring, multiple on/off functions etc.

Unique Code System

The microcontroller EEPROM allows large volume users to have a unique code. This enables Elsema to offer everyone “your own” radio control.

Case

The GLR270812R, GLR270824R can be supplied without a case, this allows the receiver to be integrated according to your needs. The C160 case (weather proof) can be used to enclose the GLR270812R, GLR270824R receiver. The receiver with a case is known as a GLR270812RE, GLR270824RE.

Products in the Range

				
GLR2701 1-Channel	GLR2701240 1-Channel, 240V	GLR2702 2-Channel	GLR2702240 2-Channel, 240V	GLR270312 GLR270324 3-Channel, 12 / 24V
				
GLR270412 GLR270424 4-Channel, 12 / 24V	GLR2708 8-Channel	GLR270812 GLR270824 8-Channel, 12 / 24V Relay Output	GLR2701SS GLR2702SS 1,2 -Channel, Open Collector Output	

Technical Data

Supply Voltage	GLR270812R : 11.0 to 14 V AC/DC Absolute maximum DC 18 Volts GLR270824R : 21.0 to 28 V AC/DC Absolute maximum DC 35 Volts Can use Elsema AC power pack (12PP or 24PP). Supply lines should be less than 3 metres long to comply with radio frequency authorities
Current Consumption	10mA standby, 340mA if all outputs “On”
Receiver Type	Single Conversion Superheterodyne
Receiving Freq	27.195MHz (Other frequencies available: 27.045, 27.145 & 27.455MHz. NB. 27.455MHz is available for Europe Only)
Type of Crystal	6.775MHz, Fundamental, 20pF, 30ppm
Operating Temperature Range	-5 to 50°C
IF Freq	320kHz
Selectivity	3dB at ±20kHz
Sensitivity	Better than 1.0uV (For output to switch on)
Type of Demodulation	Amplitude Shift Keying (ASK)
Decoding System	Microcontroller (32-bit word 4.29 x 10 ⁹ codes)
Code Combinations	4,294,967,296
Outputs	Eight change over relay outputs, each rated at 8 Amps/240 Volts
Connections	Supply & Antenna: 3-way screw type terminal block. Screw type terminal block. (8 Relay Outputs)
Antenna	50 ohms, 27.920 MHz Antenna or piece of approximately 690 mm of wire. If coaxial cable is used connect the shield to the minus on the terminal (Gnd).
Dimensions	130 x 94 x 42mm
Mounting hole size	3.97 mm or 5/32"
Mounting Hole Spacing	Length 120 mm/ Width 60 mm
Weight	240g
Microcontroller	Can be re-programmed to suit your customised needs
Useable Transmitters	All Elsema Type 27MHz GLT-... series
Useable operating range	Up to 350 metres with proper 50 ohms, 27 MHz Antenna . Up to 200 metres with 690 mm long antenna wire. Antenna wire should be extended and away from metal. Ranges assume line-of-sight operation

Block Diagram

GLR270812R/GLR270824R

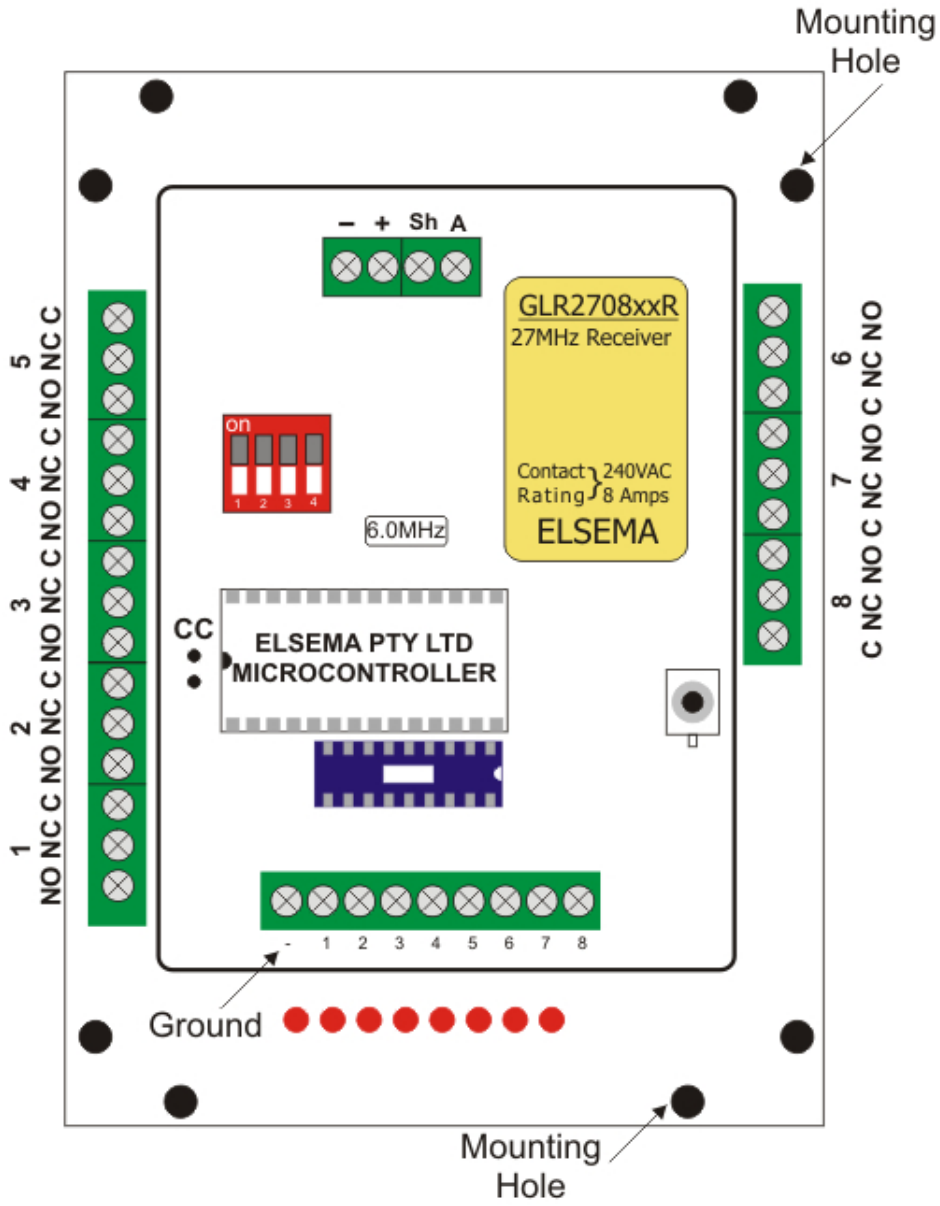

GLR270812R/GLR270824R (Old Version)

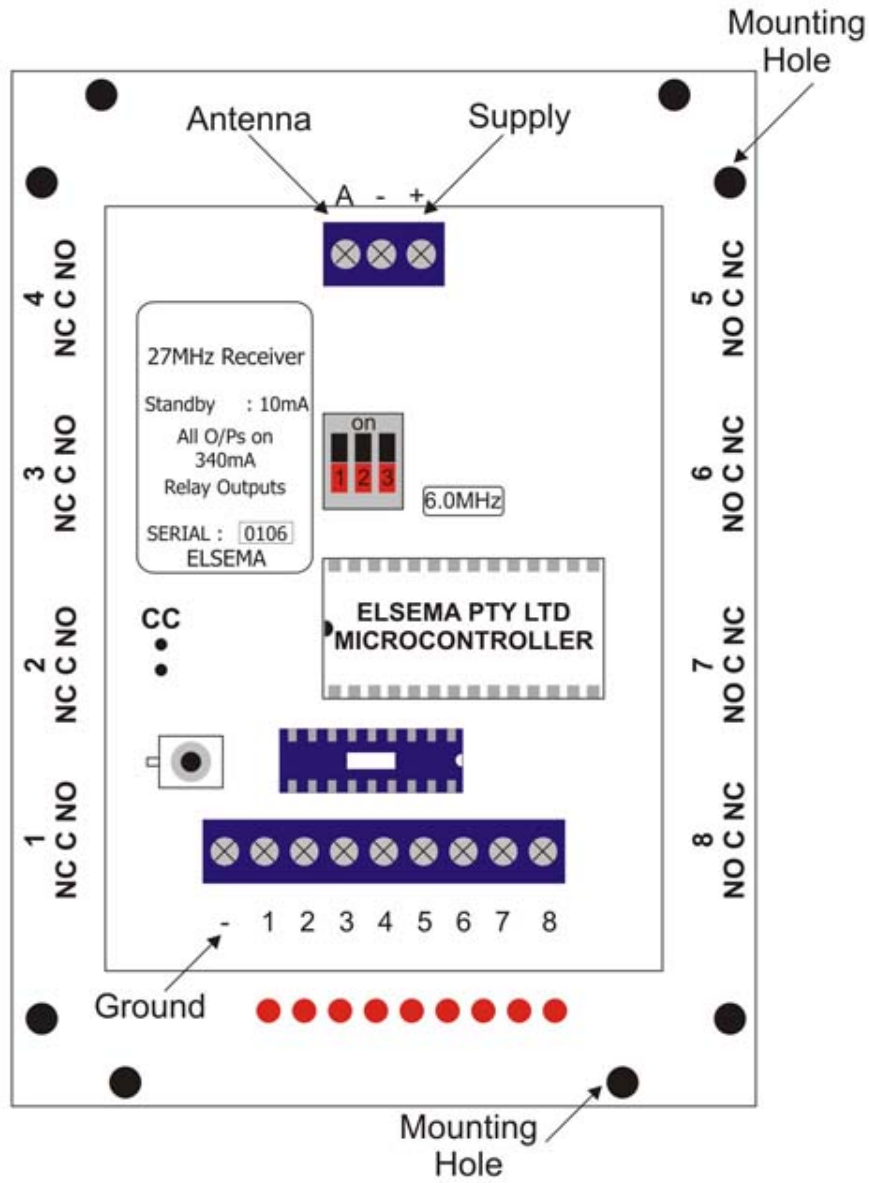

Manufactured by	Distributed by
<p>Elsema Pty Ltd 3/10 Hume Rd, Smithfield NSW 2164 Ph: 02 9609 4668 Fax: 02 9725 2663 Website: http://www.elsema.com</p>	