

# GLR2701SS, GLR2702SS

1 & 2-Channel 27MHz Gigalink™ Receiver with Open Collector Output

## Features

- One or two channel outputs
- Open Collector Output
- Available with either a Molex female or terminal block connector.
- Uses Gigalink technology, this involves using a receiver cable to program the transmitter. Some transmitters and receivers are programmed through the air. This is very risky since another person can grab your code.

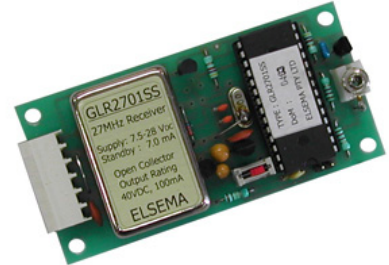

## Applications

- Security, wireless activation/deactivation of domestic or industrial alarms
- Gate operation
- Panic buttons
- Remote Activation of lights
- Simultaneous operation of multiple on/off functions

## Description

The GLR2701SS and GLR2702SS use the advanced GIGALINK™ technology to combine the decoding system and FM receiver to form the new GIGALINK™ Strip receiver. The receiver user has the choice of one or two channel outputs. The GLR2701SS has a single channel output and GLR2702SS has two channel outputs. The outputs are solid state using the BC337 transistor with open collector. When the outputs are switched to ground the receiver receives the correct code from the GIGALINK™ transmitter.

The GLR2701SS and GLR2702SS are available with either a terminal block or the Molex female connector. The terminal block is used for connecting your external wires such as the supply and the antenna, using the screw type connection.

The six-way female connector is used to integrate a 27MHz receiver onto a printed circuit board. The six-way male connector is soldered onto the printed circuit board, requiring the 27 MHz receiver. The male connector is available from Elsema as a Nylon 6-way male low profile connector, part number 6WLP or high profile connector part number 6WHP. See design dimensions page for more details.

The antenna can be a piece of wire, approximately 1 metre long (3 feet) and 1 millimetre (1/25<sup>th</sup> inch) in thickness. If a piece of wire does not give suitable reception the GLR2701SS and GLR2702SS can be connected to a coaxial cable with a proper 27MHz CB-Antenna. Elsema stocks the ANT27M 27MHz CB-Antenna.

## Code Programming

During single code programming, the dip switch selects the channel to be programmed. The table below shows the setting to select a different channel.

Dip Switch 1	Dip Switch 2	Setting Channel (Output Relay)
OFF	OFF	1
ON	OFF	2

After selecting the correct channel, the receiver channel is ready to be single code programmed.

Follow the steps outlined in the receivers instruction sheet titled single code programming to complete the code programming.

## Code Programming - Channelised

If all the receiver channels are to be programmed onto a multi channel transmitter, then follow the steps outlined in the receivers instruction sheet titled channelised code programming. This does not require the user to set the 2-way dip switch since all receiver channels will be programmed sequentially onto the transmitters channels.

The receiver power must be connected when single or channelised code programming.

When programming is completed and the GIGALINK cable is removed from the multi channel receiver-coding socket, the 2-way dip switch is used to select different output modes. This is described below.

## Different Modes for the Output

Modes are user selectable from the 2-way dipswitch. Dipswitch 1 corresponds to output channel 1 and dipswitch 2 corresponds to output channel 2.

Momentary Mode	If the dipswitch is “off” the relay will be in momentary mode.
Flipflop Mode	If the dipswitch is “on” the relay will be in flipflop mode.
Latching Mode	If latching is required (Relay stays on until power is removed) the latching link should be inserted and soldered into the two holes to the right of the 2-way dipswitch. This will enable the corresponding outputs to latch.

## Products in the Range

				
<b>GLR2701</b> 1-Channel	<b>GLR2701240</b> 1-Channel, 240V	<b>GLR2702</b> 2-Channel	<b>GLR2702240</b> 2-Channel, 240V	<b>GLR270312</b> <b>GLR270324</b> 3-Channel, 12 / 24V
				
<b>GLR270412</b> <b>GLR270424</b> 4-Channel, 12 / 24V	<b>GLR2708</b> 8-Channel	<b>GLR270812</b> <b>GLR270824</b> 8-Channel, 12 / 24V Relay Output	<b>GLR2701SS</b> <b>GLR2702SS</b> 1,2 -Channel, Open Collector Output	

**Technical Data**

Supply Voltage	7.5-28 VDC. Supply lines should be less than 3m long to comply with radio frequency authorities
Current Consumption	7 mA on standby at 12 VDC supply
Receiver Type	Dual Conversion Superheterodyne
Receiving Freq	27.195MHz (Other frequencies available: 27.045, 27.145 & 27.455MHz. NB. 27.455MHz is available for Europe Only)
Type of Crystal	10.245MHz, Fundamental, 20pf, 30ppm, 16.495MHz, Fundamental, 20pf, 30ppm
Operating Temperature Range	-5 to 50°C
1 <sup>st</sup> IF Freq	10.7MHz
2 <sup>nd</sup> IF Freq	455kHz
Selectivity	-6dB at ±5kHz, -20dB at ±6kHz
Sensitivity	1uV (for output to activate)
Image Rejection	At 26.285MHz better than -60dB
Type of Demodulation	Narrow-bandwidth Frequency Modulation (FM)
Occupied Bandwidth	±5kHz
Decoding System	Microcontroller (32-bit word 4.29 x 10 <sup>9</sup> codes)
Code Combinations	4,294,967,296
Outputs	GLR2701SS: 1 Open Collector Transistor Output GLR2702SS: 2 Open Collector Transistor Outputs
Output Transistor	Max switching 100mA/40VDC
Connections	Molex female connector, male M2373-6A connector is soldered to PCB (available from Elsema). Or 5-way screw type terminal block
Dimensions	88 x 43 x 15mm
Mounting hole size	3.97 mm or 5/32"
Mounting Hole Spacing	Length 81.28 mm (3.2"), Width 35.56 mm (1.4")
Weight	GLR2701SS: 43g GLR2702SS: 45g
Useable Transmitters	All Elsema Type 27MHz GLT-... series
Useable operating range	Up to 350m with proper 50 ohms, 27MHz CB-Antenna. Up to 200m with 1m long antenna wire. Antenna wire should be extended and away from metal. Ranges assume line-of-sight operation.

## Dimensions

The dimensions below show the position the male connector and plastic mounting studs should be when designing the GLR43301SS and GLR43302SS receiver onto a printed circuit board.

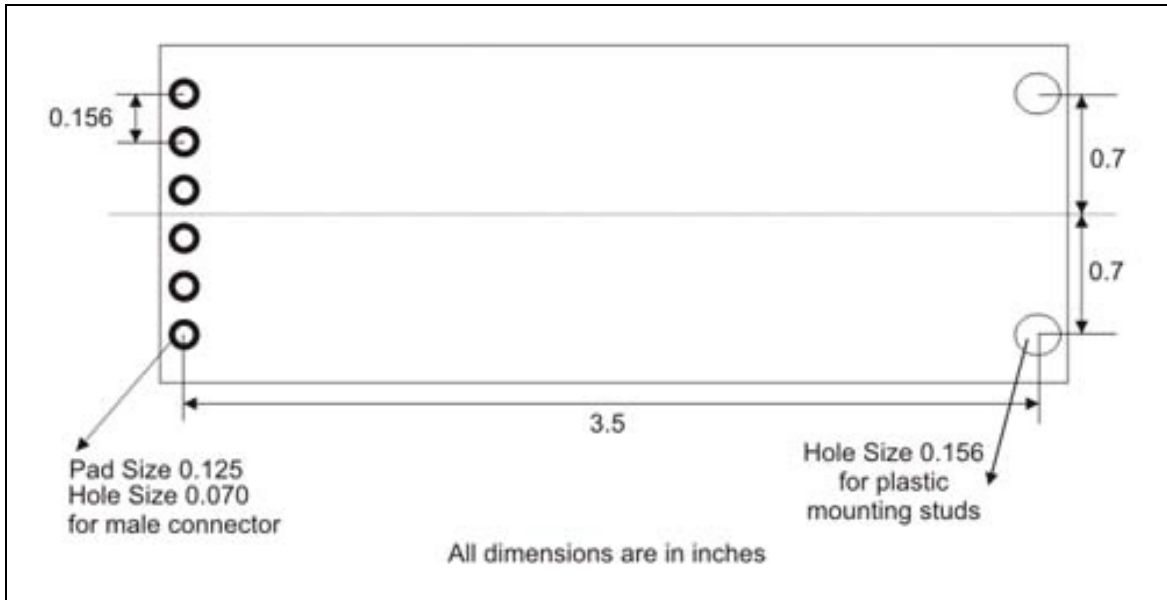

## Block Diagram

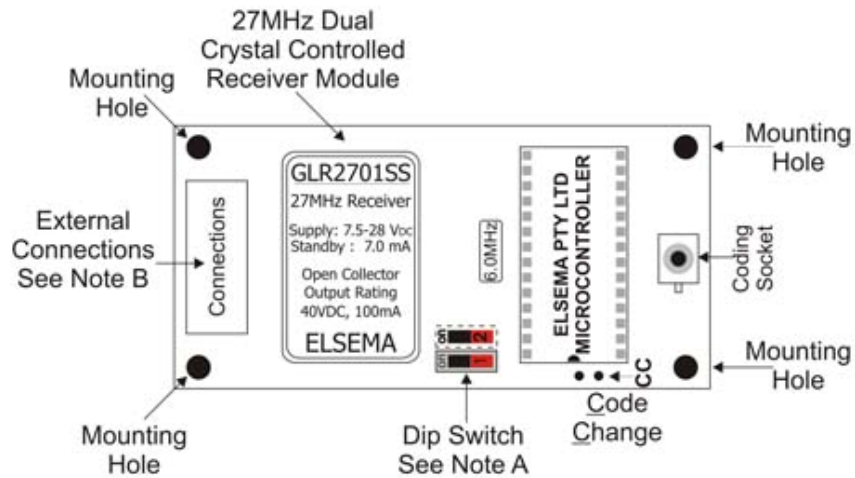

<b>Note A</b>	<b>GLR2701SS has 1-way DIP switch GLR2702SS has 2-way DIP switch</b>
<b>Note B</b>	<b>Available with Molex female connector for PCB mounting or 5-way Screw Type terminal block</b>

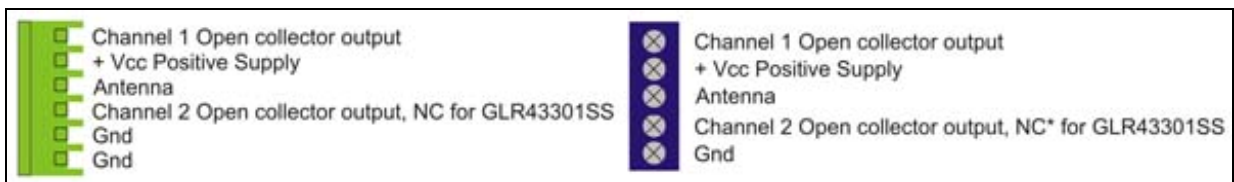

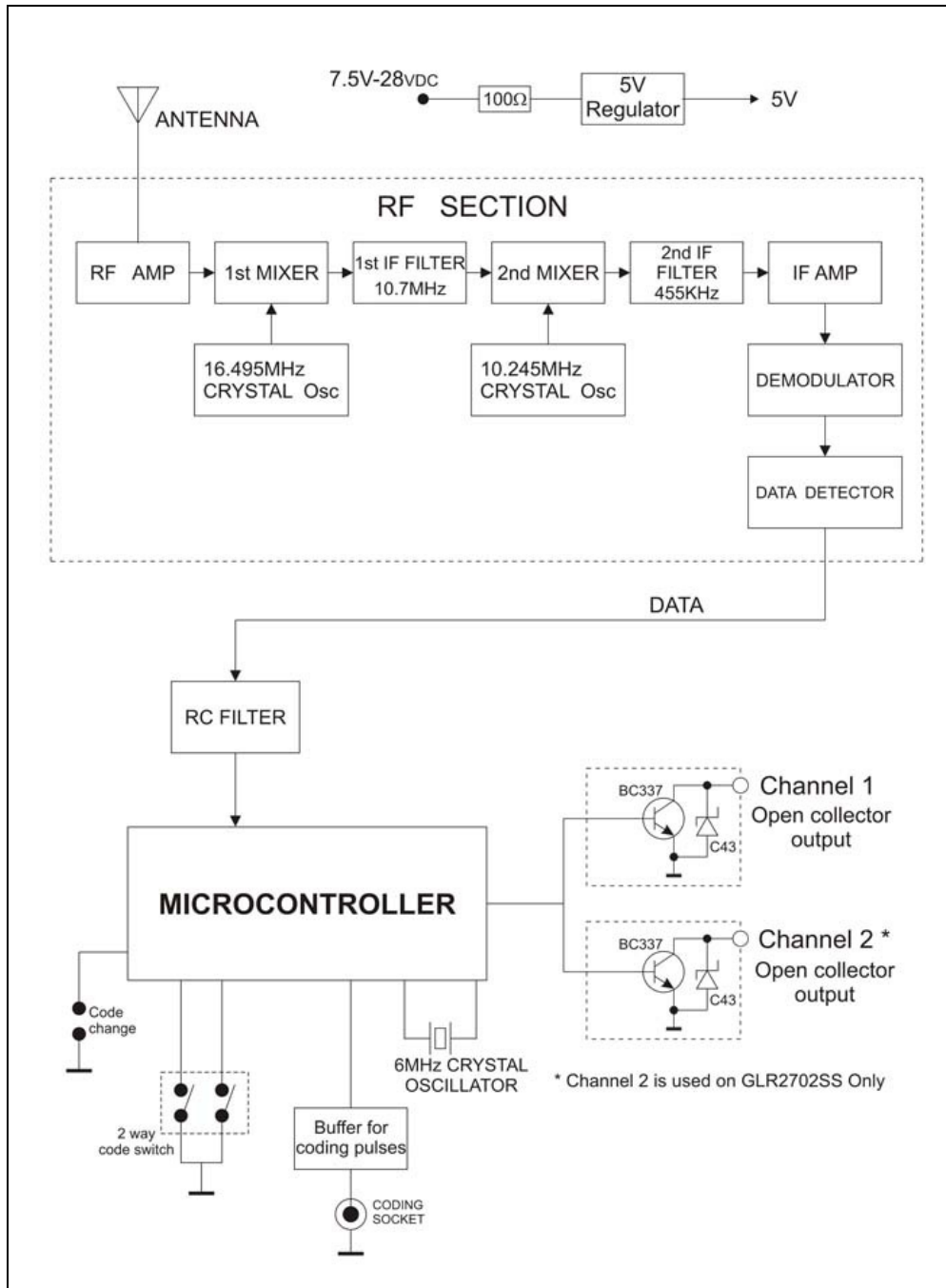

**Manufactured by**

**Elsema Pty Ltd**  
 3/10 Hume Rd, Smithfield  
 NSW 2164  
 Ph: 02 9609 4668  
 Fax: 02 9725 2663  
 Website: <http://www.elsema.com>