

GLR2701

Single Channel 27MHz Gigalink™ Receiver with Timer Controlled Relay Output

Features

- Wide supply connection – 11.0 to 28.0 Volts AC/DC
- Highly sensitive receiver input stage. When used with GLT27.... series transmitters and an operating range of 350 metres (980 ft) is possible.
- Relay Output.
- Crystal controlled for high stability and performance.
- Dual Conversion to reduce interference.
- Uses micro-controller technology that can be re-programmed to suit unique applications
- Momentary, flip-flop and latching output modes is user selectable.
- Power ON LED indicator.

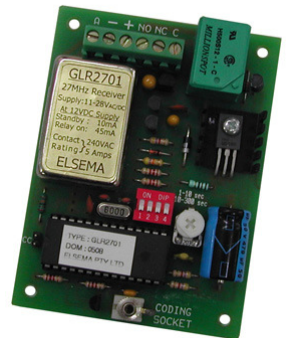

Applications

- Automatic gates, security, timer controlled outputs and simple on/off functions etc.



Description

The GIGALINK™, GLR2701 is an advanced Remote Control technology available in the world today. GIGALINK™ is an invention that has revolutionised the entire Remote Control technology including Elsema's earlier version of FMT- ... and FMR- ... series. This state-of-the-art invention brings a new dimension in the world of Remote Control technology in domestic, commercial and industrial applications.

The innovative microcontroller technology replaces the traditional dip switch coding which eliminates any possible code grabbing. Special features such as over four billion code combinations, operational over a wide voltage range, eight user selectable modes and ability to program any number of transmitters to a receiver adds up to the most advanced and secure Remote Control available.

The microcontroller in-built code programming system automatically selects the programming mode that provides flexibility in programming the receiver channel to different transmitter channels. In programming mode the receiver sends a random code to program the transmitter channel. Momentary joining the two CC pins on the receiver board sets the channel to a random code. To program the receiver to the transmitter channel(s) follow the steps outlined in the transmitter instructions.

The receiver power must be connected during code programming.

Dual Crystal Control

The GLR2701 is crystal controlled using dual conversion. Dual conversion is where the received frequency is mixed twice, using a crystal at both mixing stages. This results in less interference, enabling the receiver to operate in noisy industrial applications, improves operating performance, which allows the receiver to pass EMC and stringent radio regulations around the world.

Different Modes for the Output

Modes are user selectable from the 4-way dip switch, shown below.

DIP Switch Mode Settings	
The output relay will respond in the following manner when receiving the correct signal from a transmitter	
	"Momentary": Relay on, only while correct signal is received
	"Flip-Flop": Relay alternates at every correct incoming signal
	"Delayed Off 1": Relay on, but delayed off for 1-10 seconds, adjustable by trimpot
	"Delayed Off 2": Relay on, but delayed off for 10-300 seconds, adjustable by trimpot
	"Pulsing": Relay will pulse at 1Hz for 10-300 seconds, adjustable by trimpot
	"Latching On": Relay will energize until supply to receiver is momentarily interrupted
	"On-Off": This mode requires a 2-channel Tx. Channel 1 will always energize the relay Channel 2 will always de-energize the relay <i>To use this mode you need to do channelised code programming. Do not use single code programming.</i>
	"On-Off": This mode requires a 4-channel Tx. Channel 3 will always energize the relay Channel 4 will always de-energize the relay <i>(Mode added November 2006)</i> <i>To use this mode you need to do channelised code programming. Do not use single code programming.</i>
	"Test": Relay is energized, for test purpose only

AC/DC Supply, Antenna and Relay Connections

AC/DC power supply, antenna and relay connections are via a six-way screw-type terminal block. Do not connect the supply to the 2.5-mm coding socket since connection may damage the microcontroller.

Unique Code System

The microcontroller EEPROM allows large volume users to have a unique code. This enables Elsema to offer everyone “your own” radio control.

Case

The GLR2701 can be supplied with or without a case. The case used to enclose the receiver is Elsema's black UBB plastic case. The receiver can also be inserted to a Quick Mount enabling easy mounting to walls roof etc

Products in the Range

				
GLR2701 1-Channel	GLR2701240 1-Channel, 240V	GLR2702 2-Channel	GLR2702240 2-Channel, 240V	GLR270312 GLR270324 3-Channel, 12 / 24V
				
GLR270412 GLR270424 4-Channel, 12 / 24V	GLR2708 8-Channel	GLR270812 GLR270824 8-Channel, 12 / 24V Relay Output	GLR2701SS GLR2702SS 1,2 -Channel, Open Collector Output	

Technical Data

Supply Voltage	11.0 to 28 VDC and 10.0 to 28 VAC. Can use Elsema AC power pack (PP12 or PP24). Supply lines should be less than 3 metres long to comply with radio frequency authorities.
Current Consumption	10mA standby at 12 VDC Supply 45mA if relay "ON" at 12 VDC Supply
Receiver Type	Dual Conversion Superheterodyne
Receiving Freq	27.195MHz (Other frequencies available: 27.045, 27.145 & 27.455MHz. NB. 27.455MHz is available for Europe Only)
Type of Crystal	10.245MHz, Fundamental, 20pf, 30ppm 16.495MHz, Fundamental, 20pf, 30ppm
Operating Temperature Range	-5 to 50°C
1 st IF Freq	10.7MHz
2 nd IF Freq	455kHz
Selectivity	-6dB at ±5kHz -20dB at ±6kHz
Sensitivity	1uV (for output to activate)
Image Rejection	At 26.285MHz better than -60dB
Type of Demodulation	Narrow-bandwidth Frequency Modulation (FM)
Occupied Bandwidth	±5kHz
Decoding System	Microcontroller based 96-bit word
Code Combinations	4,294,967,296
Outputs	Change over relay output, rated at 8 Amps/240 Volts
Connections	6-way screw type terminal block
Antenna	50 ohms, 27MHz CB-Antenna or approximately 1m long & 1mm thick piece of wire
Dimensions	96 x 70 x 20mm
Mounting hole size	3.97mm or 5/32"
Weight	77g
Useable Transmitters	All Elsema Type 27MHz GLT-... series
Useable operating range	Up to 350m with proper 50 ohms, 27MHz CB-Antenna. Up to 200m with 1m long antenna wire. Antenna wire should be extended and away from metal. Ranges assume line-of-sight operation.

Block Diagram

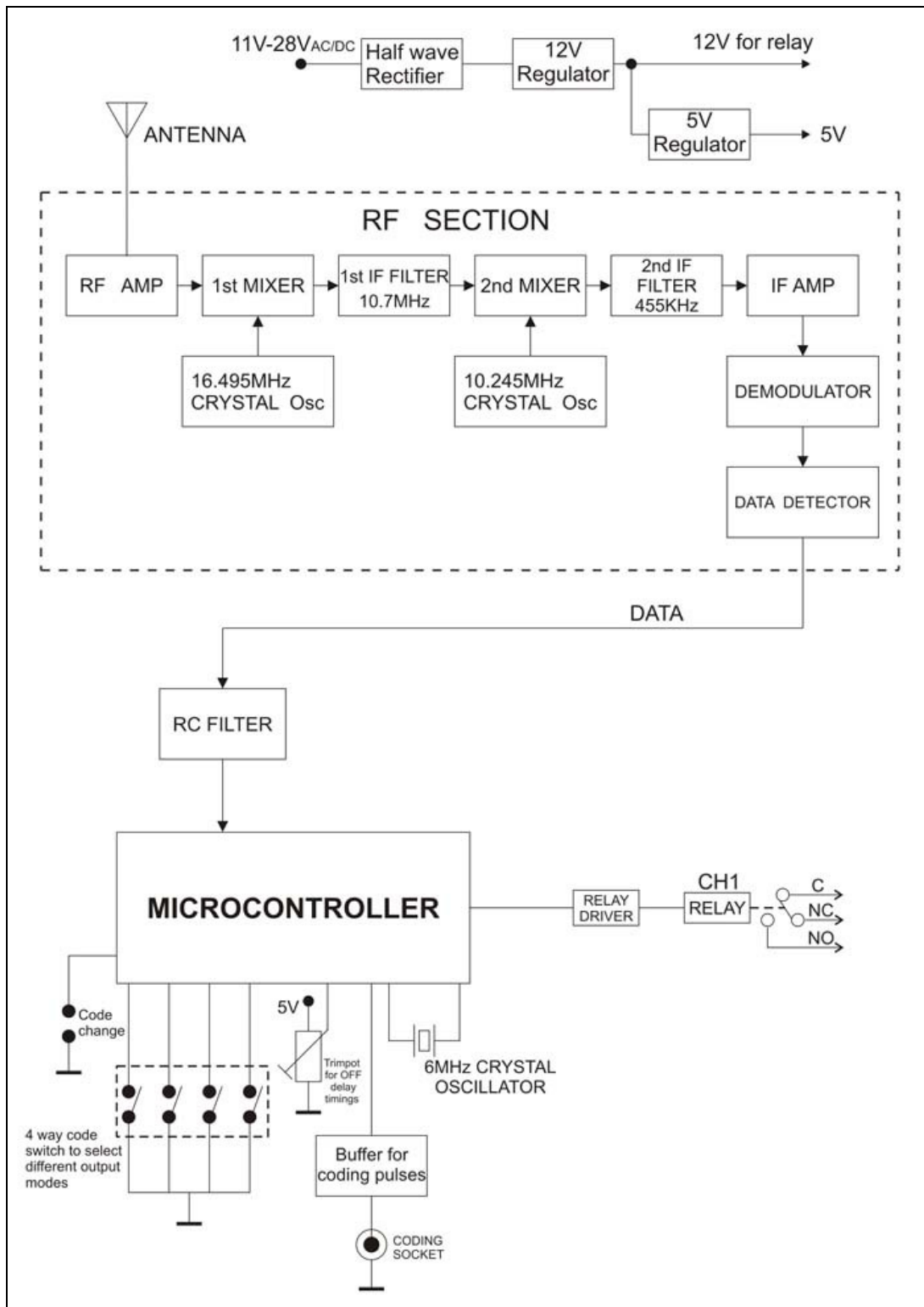

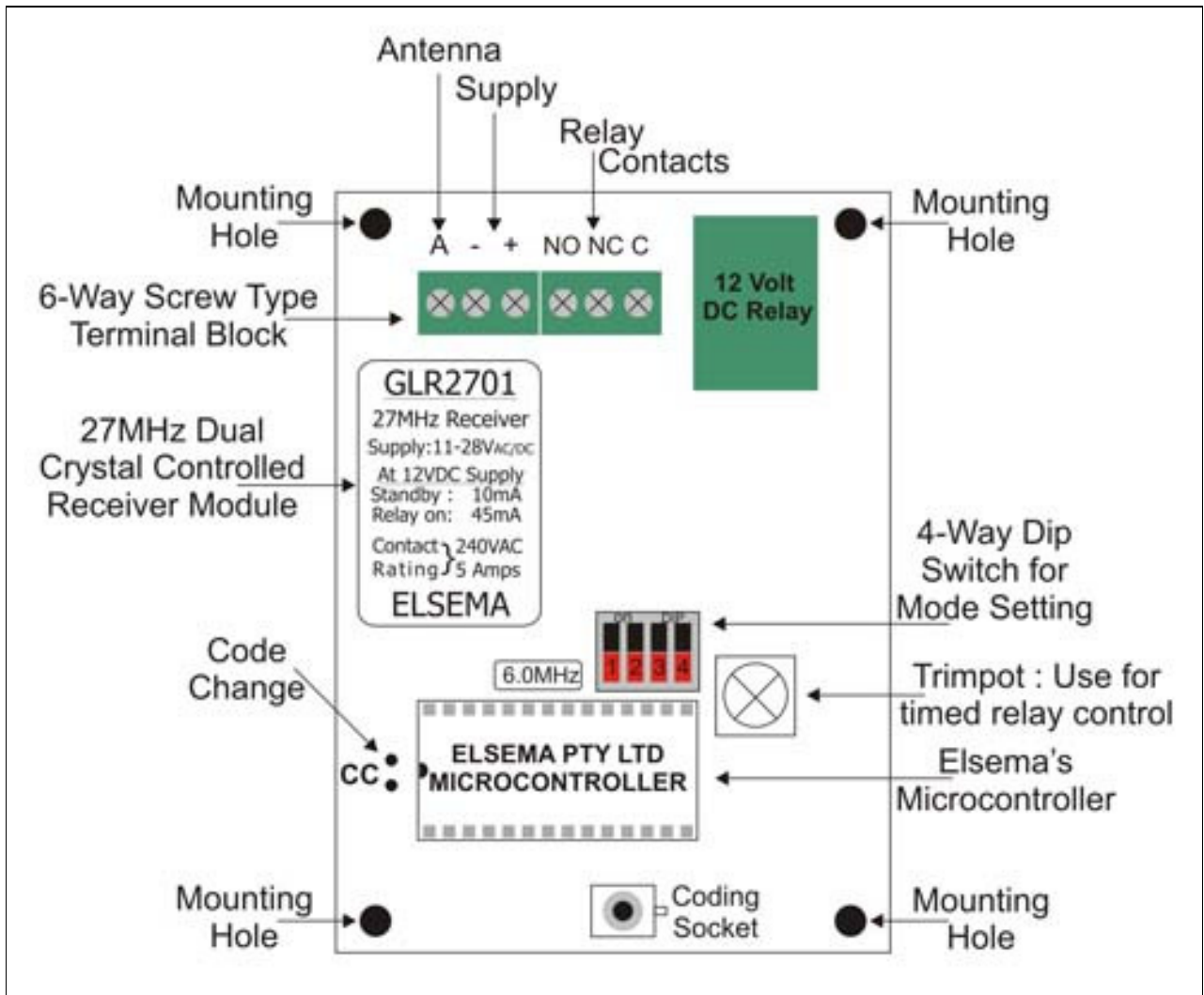

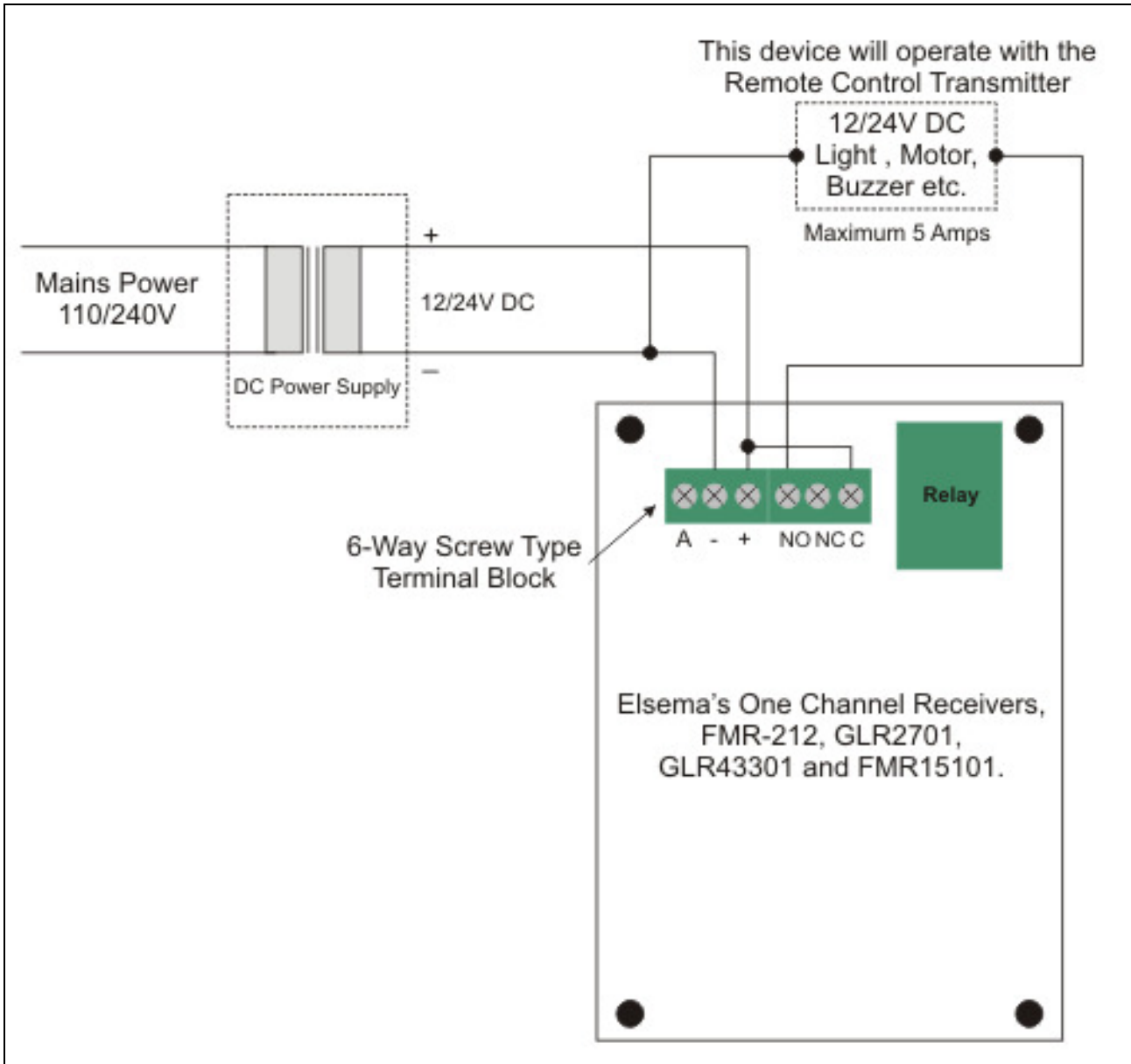
GLR2701 12/24 VAC/DC Application

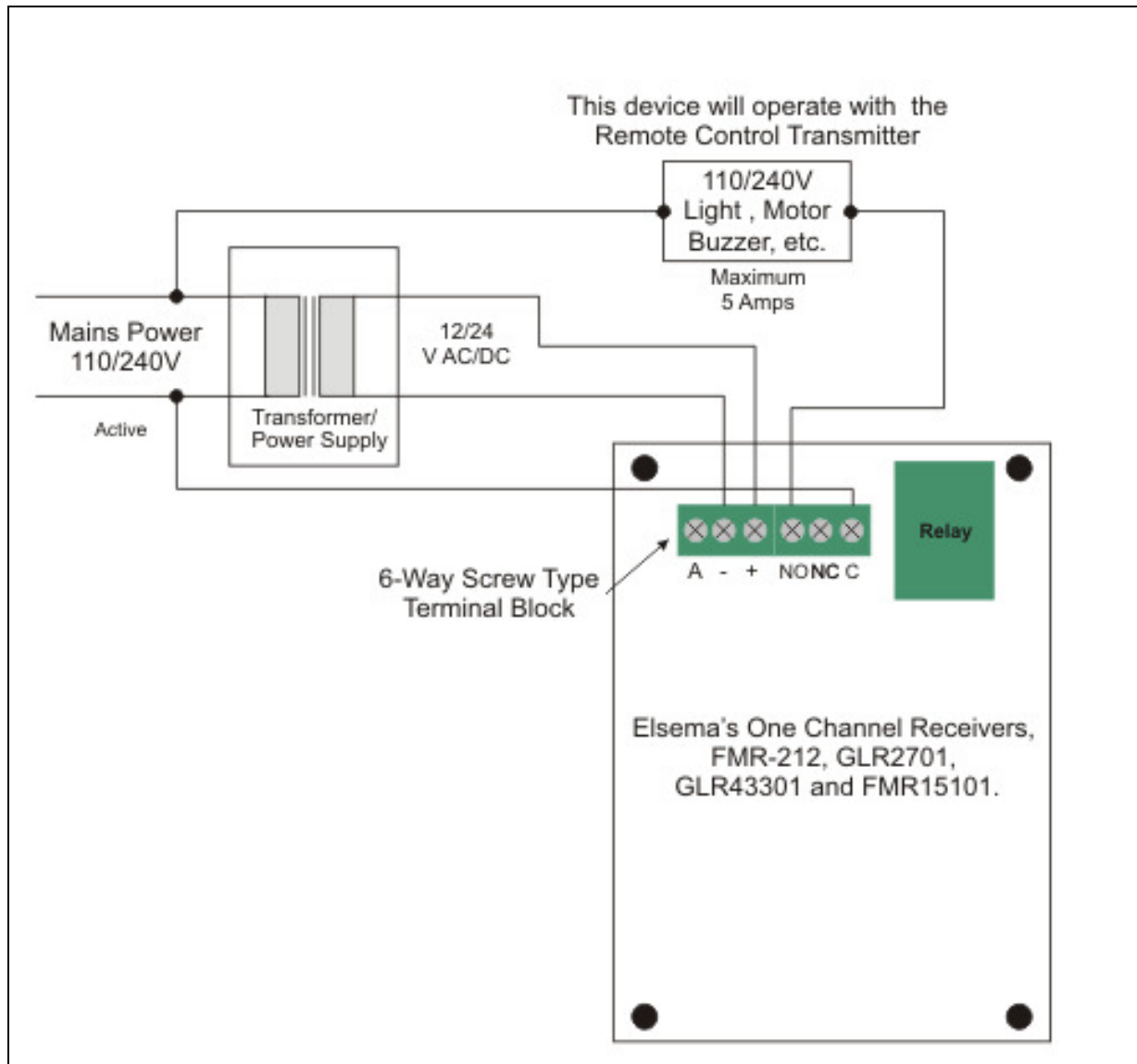
GLR2701 240/110 VAC Application**Manufactured by**

Elsesma Pty Ltd
3/10 Hume Rd, Smithfield
NSW 2164
Ph: 02 9609 4668
Fax: 02 9725 2663
Website: <http://www.elsema.com>

Distributed by