

GATCO12SCH, GATCO24SCH, GATCO12DCH, GATCO24DCH

Single / Double Gate Controller , with Battery Charger, for 12V / 24V Motor

Features

- 4 Versions: GATCO12SCH – 12V Single motor
GATCO24SCH – 24V Single motor
GATCO12DCH – 12V Double motor
GATCO24DCH – 24V Double motor
- Built-in battery charger
- Autoclose
- Motor overload control
- 10Amps safety fuse



Applications

- Control an automatic door or gate.

Description

The GATCOCH comes in four versions, GATCO12SCH (12V single motor), GATCO24SCH (24V single motor), GATCO12DCH (12V double motors), GATCO24DCH (24V double motors). It is designed to control automatic doors or gates that use DC motors with limit switches.

The GATCOCH has a built-in battery charger, push button input, photocell control, lock control and 3-minute light timer. Optional wireless operation is available with a plug in receiver.

Features include Auto Closing, Open Only and Security Closing. These features are user selectable using the on board 2-way dip switch. See table below:

Switch on 2-way code switch	ON	OFF
Switch 1	Enables Auto Close	Disables Auto Close
Switch 2	Enables Auto Close and Open Only	Disables Auto Close and Open Only
Switch 1 and Switch 2	Enables Auto Close, Open Only and Security Close	Disables Auto Close, Open Only and Security Close

Auto Closing

Enabled when switch 1 is on. The Auto Close timer can be adjusted from 6 to approximately 60 seconds by the on board trimpot called AC. Auto Close timer starts when the door/gate is opened and stopped. Input from the Photo Cell will hold-off the closing cycle, i.e. auto close timer is reset on a photocell input.

Open Only

Enabled when switch 2 is on. This feature enables the user to open the door/gate but when the door/gate is opening the remote control is disabled and the door will fully open. Door closes when auto close timer expires.

Security Closing

Enabled when switch 1 and 2 are on. The door/gate immediately closes after the photo beam is broken and the vehicle moves away from the photo beam, even if the door/gate is not fully open.

If the door/gate is opening and no vehicle passes through the door/gate then Auto Close will close the door/gate. An Auto Close time of 6 to 60 seconds can be set on the GATCOCH board using the trimpot marked AC.

Other Features***M1 Overload Trimpot***

The trimpot labeled M1 sets the amount of overload. Turn clockwise for more overload power, anti-clockwise is less overload power. M1 is for motor 1.

Overload

If an overload condition occurs on opening the door/gate will stop. If the overload occurs on the closing direction the door/gate will stop and then open.

AC Trimpot

This trimpot sets the auto close time. A time between 6 to 60 seconds can be selected.

Red LED

The Red LED labeled PC indicates that the photocell beam is broken.

Replaceable Fuse

Replaceable 240VAC 10 Amp fuse.

Safety Feature

The GATCOCH has a built-in switch off protection. The motor will switch-off after 60 seconds of continuous running. This is called the maximum run timer.

Installation Instructions

Important: Before operating the GATCOCH for the first time, check that the door/gate is in the half way position. Then press the push button. The door/gate must move in the opening direction . If the door closes, reverse motor wires at the terminal block.

Care should be taken not to cross printed circuit board with 240V wires over or under the board. This would induce spikes onto the sensitive circuitry of the printed circuit board.

GATCO12SCH / GATCO24SCH

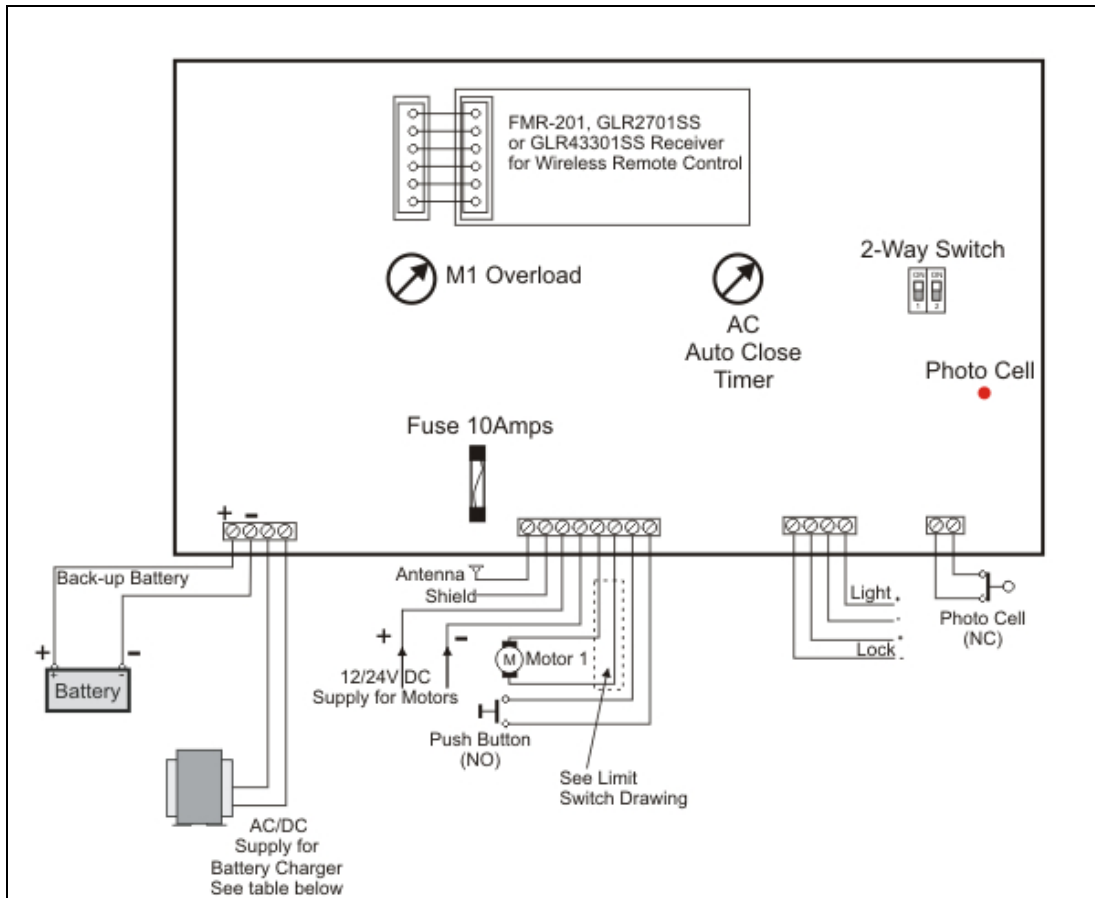

GATCO12DCH / GATCO24DCH

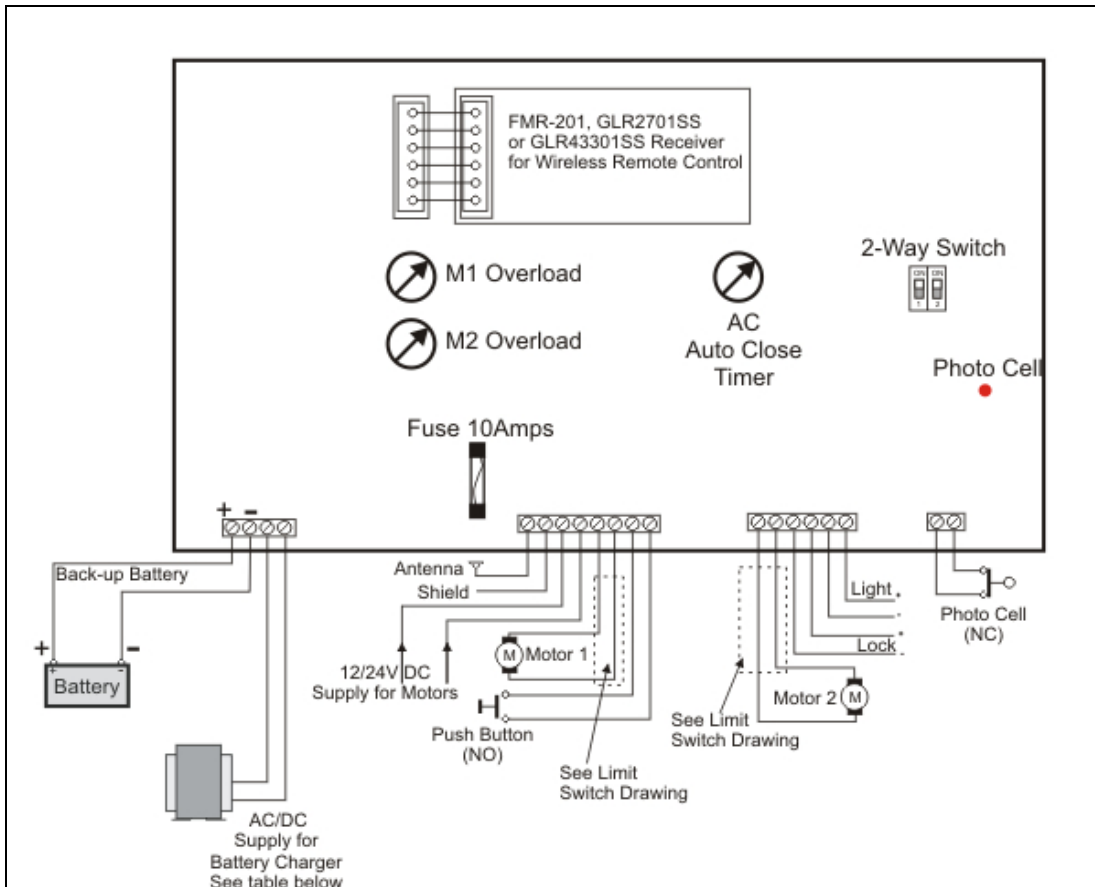

Wiring Connections

Back-up Battery

The Battery is connected here. Please be cautious of the battery polarity.

AC/DC

Connect 12V AC/DC (for GATCOCH12) or 24V AC/DC (for GATCOCH24) as the supply for the battery charger.

Version	12V	24V
AC	11.8-15V	23-28V
DC	17-24V	33-35V

Antenna

The antenna connection is used to connect an antenna for the plug in FMR-201, GLR2701SS or GLR43301SS. The antenna can be a 50 ohms Antenna or piece of approximately 1 metre of wire.

Shield

This is used if a coaxial cable is used with the antenna. The shield of the coaxial cable should be connected to this terminal.

Power + -

Connect 12 Volt DC (24 VDC for GATCO24SCH) to the terminal block marked - +. Power supply should be large enough to supply current to the motor and lock.

Motor

Motor should be rated for 12 Volt DC for GATCO12SCH. For a 24 Volt DC motor use GATCO24SCH.

Push Button Input

Push button is a normally open contact. When pressed it will start the opening or closing cycle. This push button should be waterproof for internal and external use. Waterproofing will prevent false activations, which normally occurs due to moisture inside the button. Door/gate can be held open permanently when the push button is pressed continuously.

LOCK Output

This terminal block outputs a short pulse of approximately 3 seconds on opening and closing cycle. This is used for a standard 12V lock.

To use the 3-second pulse feature, a suitable transformer needs to be connected to the GATCOCH. This transformer will supply the current that will operate the lock. Recommend transformer size is 60VA to 100VA.

Light Output

This terminal block outputs 12 volt DC (24 Volt DC for GATCO24SCH) each time the push button is pressed. This output is on for 3 minutes and can be used to operate an external light.

Photo Cell Input

Photo Cell input is normally closed contact. The photocell is used as a safety feature. If the door/gate is closing and the photo beam is broken, door/gate will stop instantly and then open fully again. Should an object be blocking the door/gate (i.e. photo cell is broken), closing cycle or auto closing is disabled.

If no photocell is used a link must be connected to the PC input terminal.







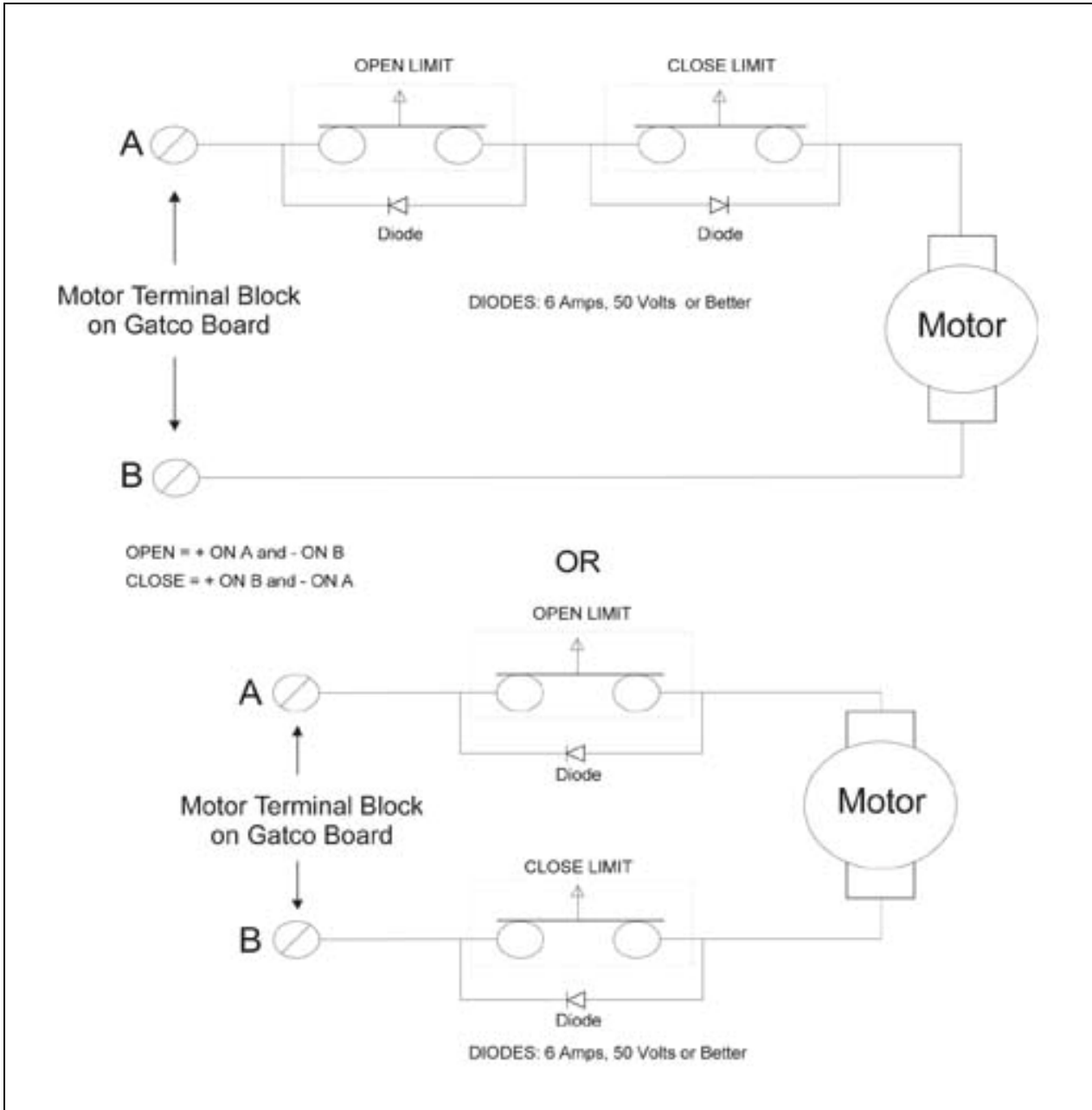









Remote Control

Remote control is achieved by inserting Elsema's FMR-201, GLR2701SS or GLR43301SS receiver. Power to the GATCOCH printed circuit board should be switched off during the installation of a receiver. The transmitter can be an FMT-301, GLT2701 or GLT43301 respectively.

Limit Switch Connection



Products in Range

			
GATCO12S 12V Single Motor	GATCO24S 24V Single Motor	GATCO12D 12V Double Motor	GATCO24D 24V Double Motor
			
GATCO12SE 12V Single Motor Card, Enclosed in a weatherproof case.	GATCO24SE 24V Single Motor Card, Enclosed in a weatherproof case.	GATCO12DE 12V Double Motor Card, Enclosed in a weatherproof case.	GATCO24DE 24V Double Motor Card, Enclosed in a weatherproof case.
			
GATCOCH12S 12V Single Motor	GATCOCH24S 24V Single Motor	GATCOCH12D 12V Double Motor	GATCOCH24D 24V Double Motor
			
<small>(Battery & Receiver Card sold separately)</small> GATCOCH12SE 12V Single Motor Card, Enclosed in a weatherproof case.	<small>(Battery & Receiver Card sold separately)</small> GATCOCH24SE 24V Single Motor Card, Enclosed in a weatherproof case.	<small>(Battery & Receiver Card sold separately)</small> GATCOCH12DE 12V Double Motor Card, Enclosed in a weatherproof case.	<small>(Battery & Receiver Card sold separately)</small> GATCOCH24DE 24V Double Motor Card, Enclosed in a weatherproof case.

To operate a single motor from a double motor controller card.

The GATCO12DCH AND GATCO24DCH control boards can be operated with a single motor only. Simply place 2 links at the specified positions as illustrated (circled in white).

Please ensure motor is connected to M1 only.

To operate double motors with no startup delays between motor 1 and motor 2.

Simply place 2 links at the specified positions as illustrated (circled in white). This will remove the startup delay between both motors.

Both Motors connected. Connect Motor 1 to M1 and Motor 2 to M2.

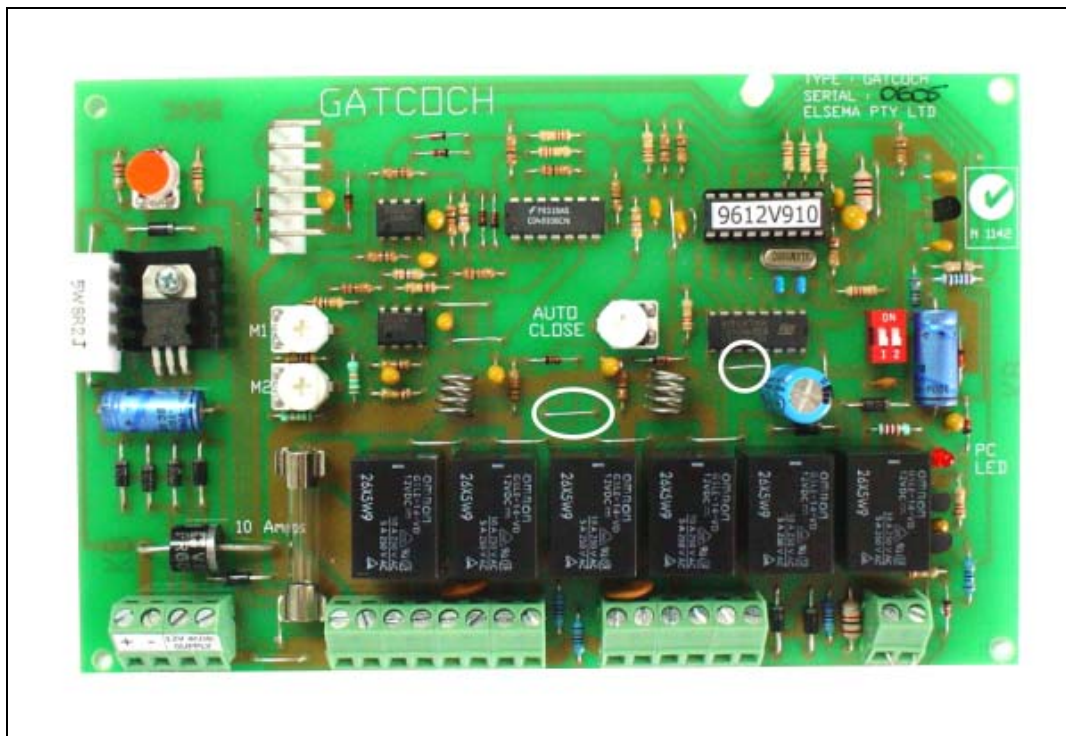

Technical Data

Power Consumption	Standby: 20mA With FMR-201 Plug-in: 30mA
M1 Trimpot Setting	0.5 - 9.5A
M2 Trimpot Setting (Double Motor only)	0.5 - 9.5A
Dimensions	146 x 116mm
Weight	160g

Manufactured by
Elsema Pty Ltd
 3/10 Hume Rd, Smithfield
 NSW 2164
 Ph: 02 9609 4668
 Fax: 02 9725 2663
 Website: <http://www.elsema.com>