

FMR15108

8-Channel 151MHz Receiver with Open Collector Outputs

Features

- Eight channel receiver with open collector outputs
- Supply voltage can be AC or DC
- Low current consumption
- Built-in noise or signal strength indicator
- User can select 8 different frequencies
- Momentary, Flip Flop and Latching modes are all user selectable
- Easy code setup with dip switch settings
- Optional QM100 bracket available for easy mounting to cases or walls.
C160 case is also available

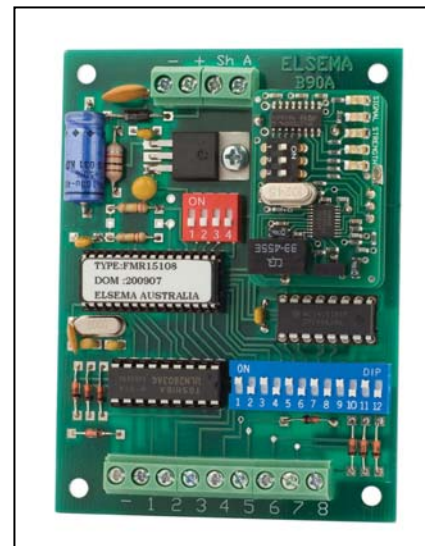

Applications

- Pump Control
- Long distance panic button
- On/Off applications in agricultural devices
- Security alarm
- Basic Telemetry eg. Water level indication

Description

The 151MHz receivers use dual conversion, narrow band FM which makes it ideal for industrial applications. Built into the receiver is a noise and signal strength indicator. The user selectable frequency synthesizer allows for easy installation on a frequency that is not in use, allowing optimal performance in the receiving range.

The receiver outputs are open collectors that are switched to ground when activated.

Different Modes for each Output

Modes are user selectable from the 4-way dip switch, shown below.

DIP Switch Mode Settings	
The output relay will respond in the following manner when receiving the correct signal from a transmitter	
	"All Momentary": Relay on, only while correct signal is received
	"All Flip-Flop": Outputs alternate at every correct incoming signal
	"Momentary & Flip-Flop": Outputs 1-4 are momentary & 5-8 are flip-flop
	"Latching on": Outputs will be on until supply to receiver is momentarily interrupted
	"Momentary & Flip-Flop": Outputs 1-6 are momentary & 7-8 are flip-flop
	"Momentary & Flip-Flop": Outputs 1-2 are momentary & 3-8 are flip-flop
	"Momentary & Flip-Flop": Outputs 1-3 are momentary & 4-8 are flip-flop
	"Latching on": Output 1 is latching & 2-8 are momentary
	"Latching on": Output 1-7 is latching & 8 is momentary. <i>Mode added on 21/05/07</i>

Coding

The 12 way dip switch on the receiver sets the 12 bit unique code for the system. This has to be matched to that on the transmitter.

Signal Strength Indicator

The 151MHz receivers have five blue LED's on the board. The table below indicates the level of the valid transmitted signal.

5 LED's on	-70dBm	Very Strong signal	Very Reliable operating conditions
4 LED's on	-75dBm	Very Strong signal	Very Reliable operating conditions
3 LED's on	-80dBm	Very Strong signal	Very Reliable operating conditions
2 LED's on	-90dBm	Strong signal	Very Reliable operating conditions
1 LED on	-100dBm	Good signal	Reliable operating conditions

Noise Strength Indicator

If more than 1 led is "ON" without a valid transmission, this indicates that there is noise on the frequency selected.

Change the **3-way dipswitch** on the **receiver module** to select a different frequency.

Following is a table with the Dipswitch settings and the corresponding frequencies.

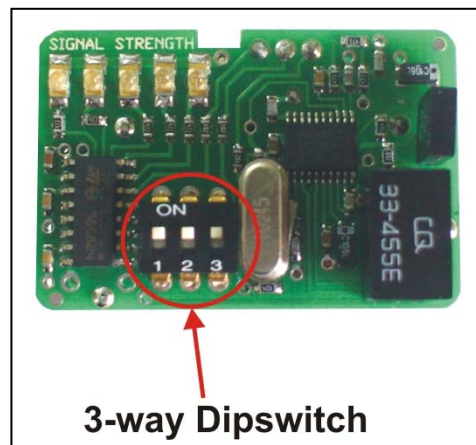





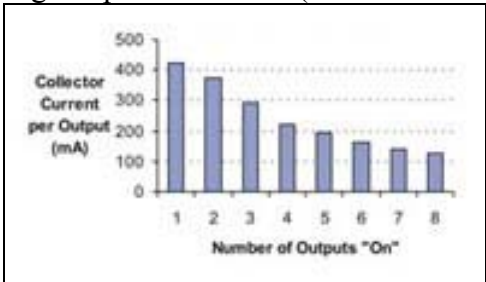



Frequency	1	2	3
151.600 MHz	On	On	On
152.375 MHz	Off	On	On
151.775 MHz	On	Off	On
151.400 MHz	Off	Off	On
151.175MHz	On	On	Off
151.025 MHz	Off	On	Off
150.900 MHz	On	Off	Off
150.825 MHz	Off	Off	Off

Technical Data

Supply Voltage	11.0 to 28.0 Volts AC/DC. Can use Elsema 12-volt AC power pack (PP12).Supply lines should be less than 3 metres long to comply with radio frequency authorities.																		
Current Consumption	35mA Standby at 12VDC, 45mA if all outputs “On”																		
Receiver Type	Single Conversion Superheterodyne																		
Receiving Freq	151.6MHz (8 selectable frequencies. See table above)																		
Oscillation System	VCO with 10ppm crystal controlled reference oscillator																		
Operating Temperature Range	-5 to 50°C																		
IF Freq	10.7MHz																		
Sensitivity	Better than 0.5uV (For output to activate)																		
Selectivity	Better than -6dB at ±25kHz																		
Type of Demodulation	Narrow-Bandwidth Frequency Modulation (FM)																		
Occupied Bandwidth	25kHz at -20dB																		
Output	<p>Eight Open Collectors (See chart for Collector Currents)</p>  <table border="1"> <caption>Collector Current per Output (mA) vs Number of Outputs "On"</caption> <thead> <tr> <th>Number of Outputs "On"</th> <th>Collector Current per Output (mA)</th> </tr> </thead> <tbody> <tr><td>1</td><td>420</td></tr> <tr><td>2</td><td>380</td></tr> <tr><td>3</td><td>300</td></tr> <tr><td>4</td><td>220</td></tr> <tr><td>5</td><td>180</td></tr> <tr><td>6</td><td>150</td></tr> <tr><td>7</td><td>130</td></tr> <tr><td>8</td><td>125</td></tr> </tbody> </table> <p>Chart indicates that eight outputs can be ON simultaneously with each output collector current being 125mA. Outputs can hold 40 Volts in “Off” state.</p>	Number of Outputs "On"	Collector Current per Output (mA)	1	420	2	380	3	300	4	220	5	180	6	150	7	130	8	125
Number of Outputs "On"	Collector Current per Output (mA)																		
1	420																		
2	380																		
3	300																		
4	220																		
5	180																		
6	150																		
7	130																		
8	125																		
Connections	Supply, Antenna & Outputs - Screw type terminal block																		
Antenna	50Ω, 151MHz Antenna, Elsema ANT151M for maximum performance A piece of approximately 1metre wire can be used for short range applications																		
Dimensions	90 X 70 X 15 mm																		
Mounting hole size	3.97 mm or 5/32"																		
Weight	83g																		
Microcontroller	Can be re-programmed to suit your customised needs																		
Useable Transmitters	All FMT151 series (with correct setting on the dip switch). See Transmitter datasheet for details.																		
Useable operating range	Up to 5000 metres, depending on installation and type of antenna used. Recommended Antenna is Elsema ANT151M																		

Products in the Range

			
<p>FMR15101 1-Channel</p>	<p>FMR15102 2-Channel</p>	<p>FMR15101240 1- Channel 240VAC Supply</p>	<p>FMR15102240 2- Channel 240VAC Supply</p>
			
<p>FMR15104 4-Channel</p>	<p>FMR15108 8-Channel</p>	<p>FMR1510812R 8-Channel, 12V Supply</p>	<p>FMR1510824R 8-Channel, 24V Supply</p>

Block Diagram

FMR15108

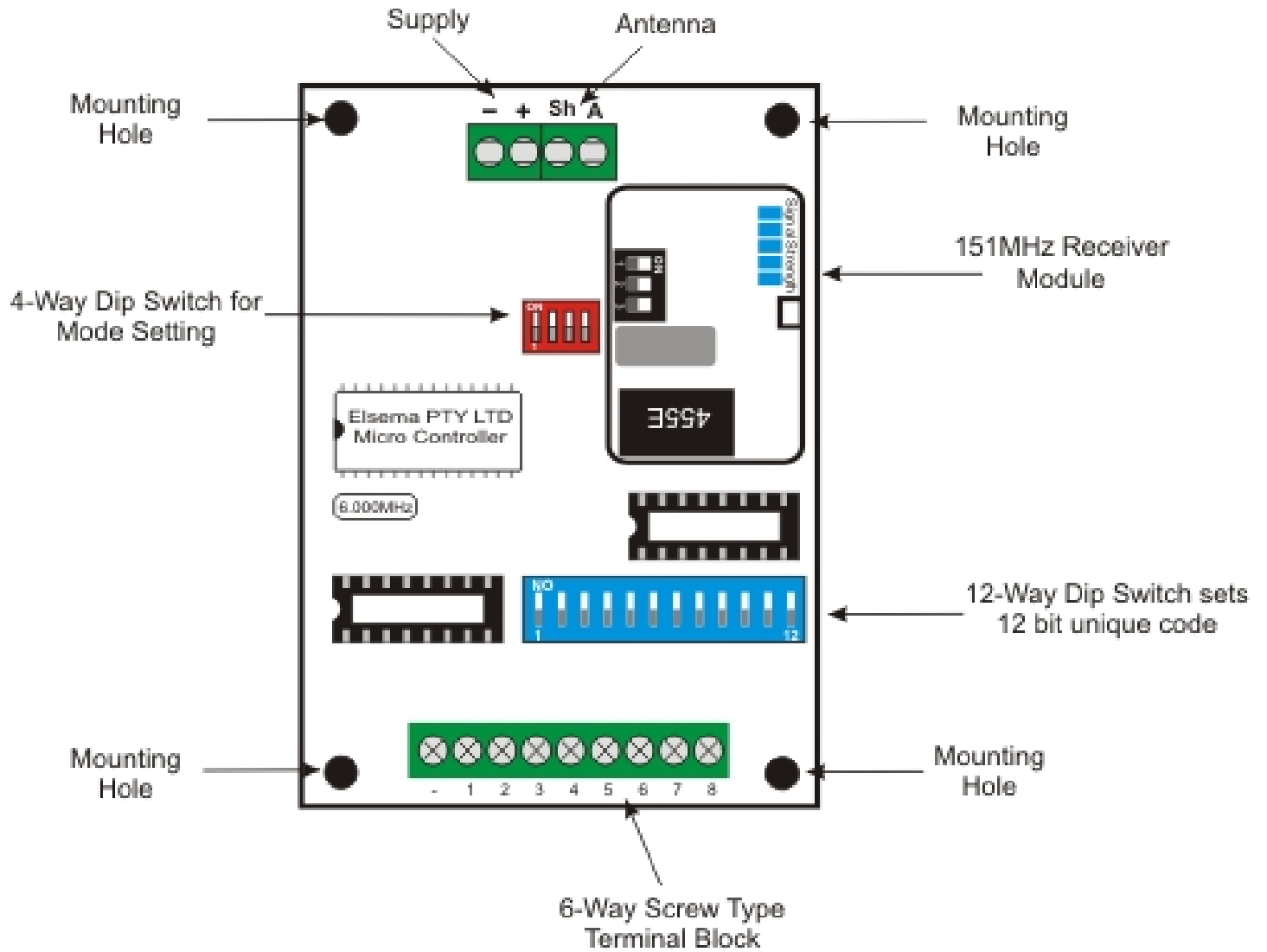

Application Notes

Care should be taken with the solid-state outputs that they are protected from inductive loads. This is done by connecting diodes across your DC inductive load.

Inductive loads such as DC relays must be clamped with a diode across the relay coil. If this is not done the spikes generated by the DC relay will lock-up the receiver. When a lock-up occurs you will need to remove the power and re-connect it.

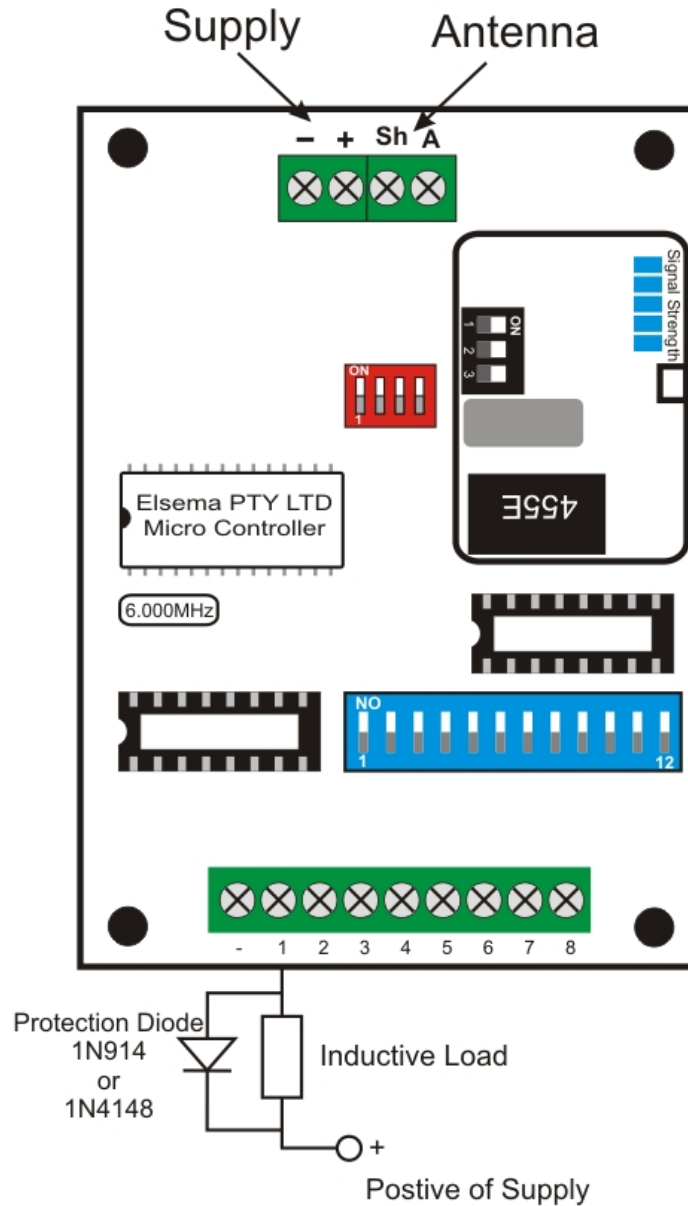

Manufactured by

Esema Pty Ltd

3/10 Hume Rd, Smithfield
NSW 2164

Ph: 02 9609 4668

Fax: 02 9725 2663

Website: <http://www.elsema.com>