

FMR-203, FMR-203SS

27MHz, 2-Channel FM Receiver

Features

- 2 versions - **FMR-203** (1 Digital output +5 Volts and 1 Solid state output)
-**FMR-203SS** (2 Solid state outputs)
- Crystal Controlled
- Low supply voltage, highest reliability, low power drain
- Two Channel Receiver

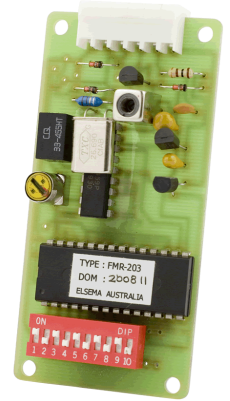

Description

The FMR-203 is a **crystal controlled** two channel receiver (where one is a digital output and one is an open collector output), comprising of receiving, decoding and open collector output sections. A specially designed LARGE SCALE INTEGRATED CIRCUIT (LSI) is employed in the decoder section, which ensures operation at low supply voltage, highest reliability, associated with very low power drain.

The receiver works on a **digitally encoded** 27 MHz frequency modulated (FM) signal. It may be used in an application that requires the 27MHz receiver to be mounted on a printed circuit board.

If the code of the input signal (from a transmitter) matches the setting of the coding switch on the receiver (up to **1024 combinations**), an output is obtained i.e. the open collector is switched to ground.

Connection to the receiver is via a **six-way female connector**. The male connector can be soldered onto any type of printed circuit board, requiring a 27 MHz receiver. The male connector is available as a Nylon 6-way male low profile connector, part number 6WLP or high profile connector part number 6WHP. See design dimensions page for more details.

Elsema's ANT27MHz series antennas will give a reliable control range of up to 200 metres, when used with Elsema's FMT-301, FMT-302 and FMT-304 transmitters.

The default mode is in **momentary mode**, i.e. the output transistor is only activated while the correct signal is received.

Care must be taken, not to bring a receiver near strong magnetic fields, such as DC-Motors, speakers, magnets for reed switches, transformers etc. as it would magnetise the coils and may cause severe de-tuning.

The FMR-203 has 2 versions:

Versions	FMR-203	FMR-203SS
Outputs	1 Solid state output and 1 digital output (+5V)	2 Solid state outputs.

Products in the Range

				
<p>FMR-201 Single Channel Receiver with Open Collector Output</p>	<p>FMR-203 2-Channel PCB Strip Receiver</p>	<p>FMR-212 Single Channel Receiver with Relay Output</p>	<p>FMR-212T Single Channel Receiver with Timer Controlled Relay Output</p>	<p>FMR-24001 Single Channel 240VAC Receiver with Relay Output</p>
				
<p>FMR-24002 2-Channel 240VAC Receiver with 2 Relay Outputs</p>	<p>FMR-202 2-Channel Receiver with 2 Relay Outputs</p>	<p>FMR204-12 4-Channel 12V Receiver with 4 Relay Outputs</p>	<p>FMR204-24 4-Channel 24V Receiver with 4 Relay Outputs</p>	<p>FMR-204/16 4/16 Channel Receiver with Open Collector Outputs</p>
				
<p>FMR-232R Computer Receiver with 2 Relay Outputs & Database Software</p>	<p>FMR-100 Receiver for Multi-Channel System</p>	<p>RXD-101 Decoder for Multi-Channel System</p>		

Technical Data

Supply Voltage	7.5-28 Volts DC
Current Consumption	10mA stand by
Receiving Frequency	27.145MHz (Other frequencies available: 27.045, 27.195 & 27.455MHz. NB. 27.455MHz is available for Europe Only)
Type of Crystal Used	26.690MHz, 3rd overtone, 20pF, 30ppm at 0-50°C
IF Frequency	455kHz
Selectivity	At least -40dB at ±10kHz
Sensitivity	Better than 1uV (for transistor to switch on)
Type of Demodulation	Narrow-Bandwidth Frequency Modulation (FM)
Occupied Bandwidth	±2.5kHz
Decoding System	Onboard 10-way coding switch (1024 digital channels)
Output	Transistor output maximum-switching 100mA/40VDC Digital output is +5 Volts when activated.
Connections	6-way female connector type Male connector is soldered to a PCB
Antenna	Elsema's ANT27MHz series antennas or piece of approximately 300 mm long wire for short range applications.
Dimensions	88 x 43 x 15mm
Mounting Hole Size	3.97mm or 5/32"
Mounting Hole Spacing	Length 81.28mm (3.2") Width 35.56mm (1.4")
Weight	32g
Compatible Transmitters	All Elsema type FMT-... 27MHz series and KEY-3.. series

NB:

All input & outputs are protected against possible transients or static charges

If antenna is a piece of wire, install away from metal parts

Keep coils L1 & L2 away from magnetic components such as speakers, motors, transformers etc

Do not change factory tuning of L1 & L2 coils

Circuit Diagram

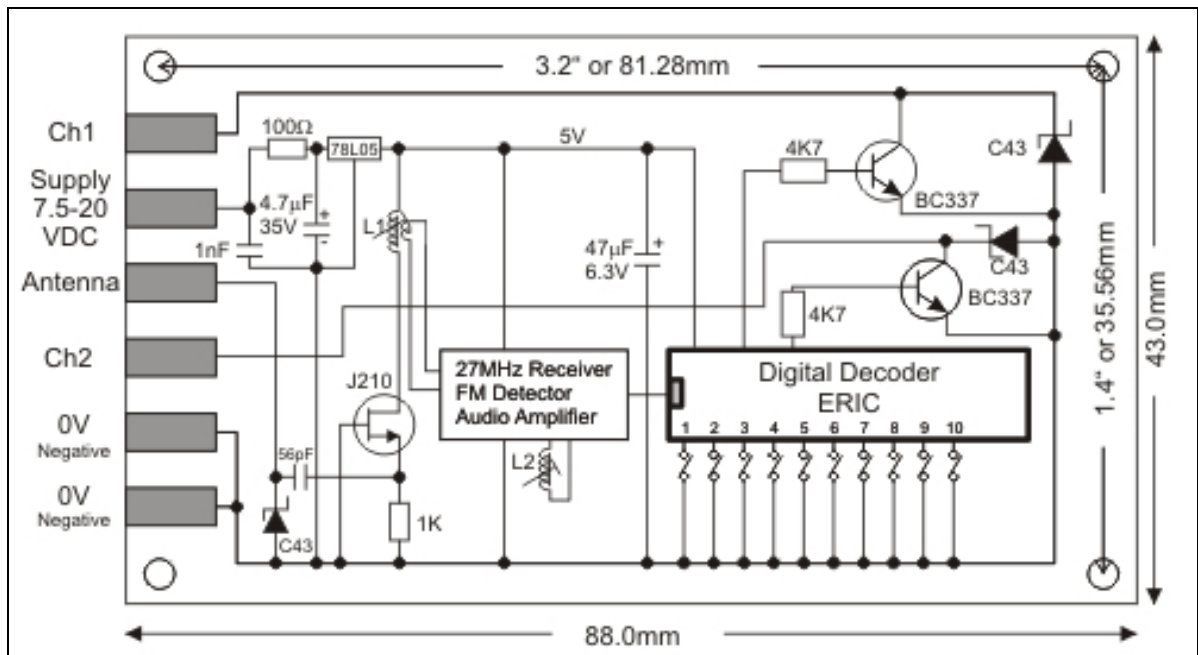

Dimensions

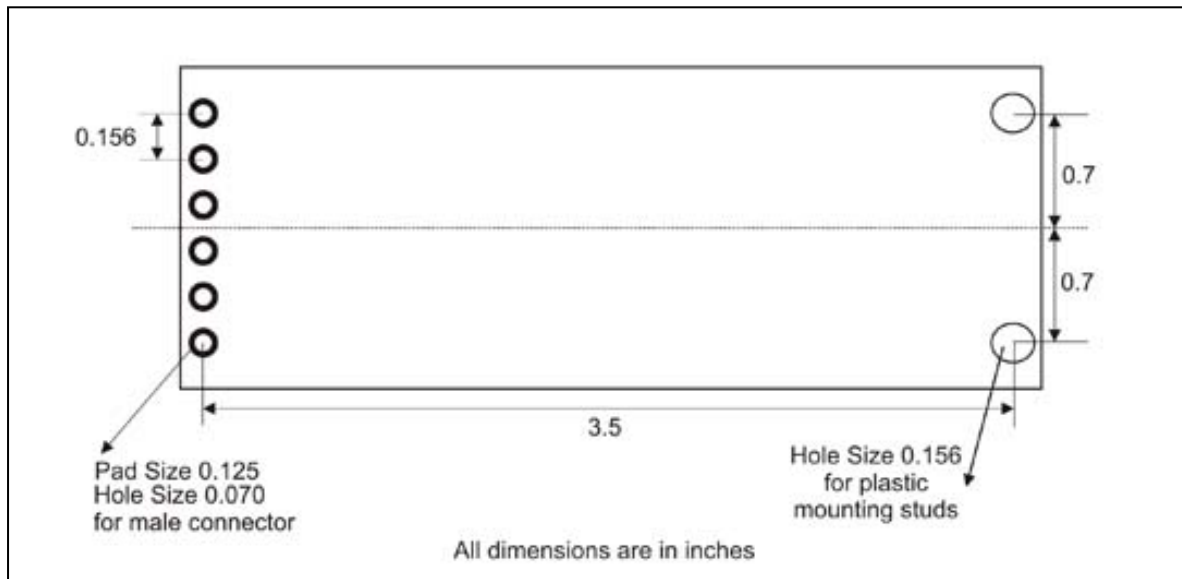

Manufactured by

Elsema Pty Ltd
 3/10 Hume Rd, Smithfield
 NSW 2164
 Ph: 02 9609 4668
 Fax: 02 9725 2663
 Website: <http://www.elsema.com>