

1PHE-3WIRE, 1PHE-4wire

Single Phase Control Board

Features

- 2 versions - **1PHE-3 wire** and **1PHE-4 wire**
- Built-in push buttons
- High-rated contactors for direct connection to the motor
- Separate key lock switch - change from Auto, Manual and Off

Application

- Control of automatic doors or gates that operate high current single-phase motors
- Heavy Roller Doors or Sliding Gates

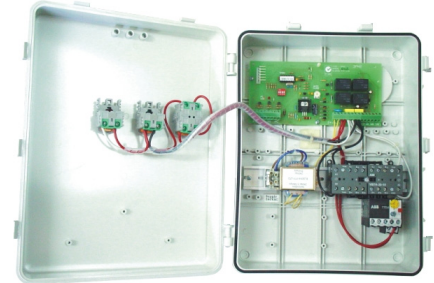

The 1-Phase Control Board is used to control automatic doors or gates that operate with high current single-phase motors in high usage residential and commercial access. For example, heavy roller doors or sliding gates. The control card is available as **1PHE-3 wire** and **1PHE-4 wire**.







Part Number	Number of Motor Wires	Wire Connections
1PHE-3Wire	3 Wire Motor	2 Active, 1 Neutral
1PHE-4Wire	4 Wire Motor	2 Active, 2 Neutral

Both wirings are available in a weatherproof box which has built in push buttons and special high rated contactors for direct connection to the motor. The two built in push buttons each control up and down. There is also a separate key lock switch that is used to change from Auto, Manual and Off.

- **Auto** operation disables the two push buttons on the weatherproof case. While the PCB push button (PB), PCB external down only push button (DO), PCB photo cell (PC) and the remote control transmitter are enabled. The PCB connections are via a terminal block on the controller card **Printed Circuit Board**.
- **Manual** operation enables the two push buttons on the case and the PCB Down Only push button. The PCB push button, PCB photo cell and the remote control transmitter are disabled.
- **Off** turns the card off. Both Auto and manual features are disabled.

The single phase configuration can control a motor up to 8 Amps. Higher current ratings are available on request.

There is a built-in PCB 4-way dipswitch that can be used to configure different functions. Below is a description of the different functions available.

	Auto Closing enabled
	Auto Closing and Open Only enabled
	Auto Closing, Open Only enabled and Security Close enabled
	Auto Close, Open Only and Special Security Close
	Open Only enabled
	Open Only and Security Close enabled

Auto Closing is when the door automatically closes after a pre-set time. The pre-set time is user selectable between 3 to 60 seconds by a variable trimpot on the printed circuit board. The trimpot is labeled AC (Auto Closing). The photocell will reset the auto close timer. The door can still be closed with the PCB push button and the PCB down only push button. Auto close timer starts when door is in the up-limit switch (fully opened).

Open Only is where the door can be opened with the PCB push button, PCB down only push button, photocell and the remote control transmitter. When the door is opening or fully opened the PCB push button and remote control transmitter are disabled. Door can only close by the activation of PCB down only push button.

Security Closing

Enabled when switch 3 is on. The door/gate immediately closes after the photo beam is broken and the vehicle moves away from the photo beam, even if the door/gate is not fully open.

If the door/gate is opening and no vehicle passes through the door/gate then Auto Close will close the door/gate. An Auto Close time of 3 to 60 seconds can be set on the SLD board using the trimpot marked AC.

Special Security Close

Enabled when switch 4 is on. Same as Security Close except door does not reverse to open when Photo beam is broken. This is to prevent car-tailing on more secure sites.

1PHE

Technical and Installation Instruction

All power connected to the card should be **disconnected before** installation or adding extra options.

Options

The PCB push button needs to be normally open contact (NO).

The PCB down only push button needs to be normally open contact (NO).

The PCB photocell needs to be a normally closed contact (NC).

For remote control operation an Elsema FMR-201, GLR2701SS or GLR43301SS receiver needs to be inserted into the control card. When the door is opening the remote controller can stop it anywhere but not when it's closing.

Technical Specifications

Controller Card Supply:	Operates from 24 Volt AC, 100 mA. Use 24 Volt AC, 1 Amp when connecting your own contactors.
LED indicator:	Controller card has an option to connect two LED's. These LED's will indicate the doors position. Either open or closed.
Auto Close:	User selectable from 3 to 60 seconds.
Interlock:	Controller card with the weatherproof box has a built-in mechanical and electrical interlock. This feature prevents users from pressing the up and down button at the same time.
Limit Switches:	Door stops by using two limit switches. One for open and the other for closed position. Limit switches need to be normally closed contacts (NC).
Overload:	Controller card with the weatherproof box has a built-in current overload. This is user selectable from 6 to 8 amps for 240 volt motors. Higher current ratings are available upon request.
Connections:	240 Volt 4 wire motors see diagram titled Wiring Diagram for 1PHE with 240V 4 wire Motor 240 Volt 3 wire motors see diagram titled Wiring Diagram for 1PHE with 240V 3 wire Motor
Safety feature:	If controller or motor are faulty the controller card will shut down after 60 seconds.
Dimensions:	320 X 250 X 120 mm

Wiring Diagram for Contactors, on a 240-Volt 3 wire Motor Application

Wiring Diagram for
1PHE-3Wire used with 240V
3 Wire Motor

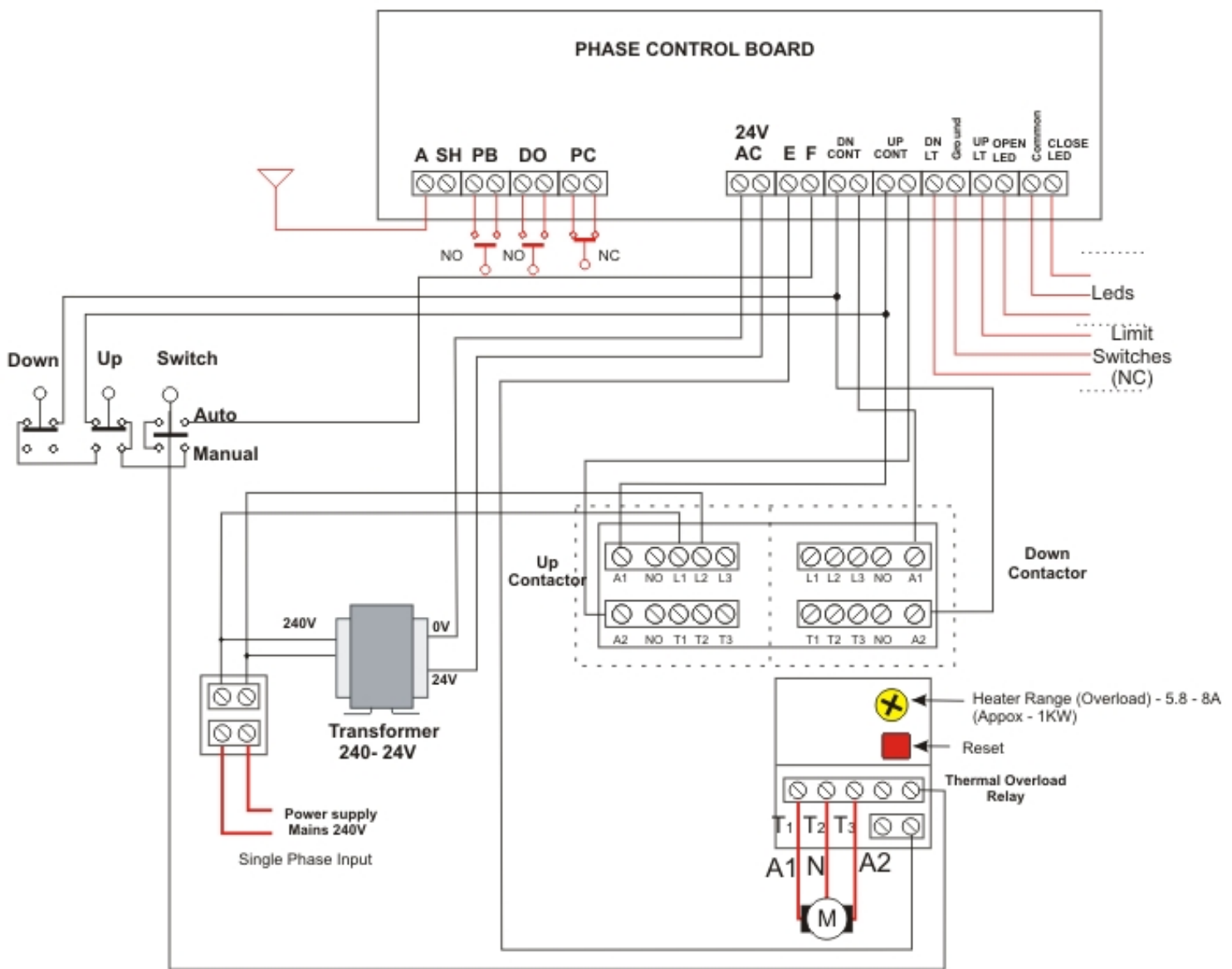

Connections in red will be done by the user

Wiring Diagram for Contactors, on a 240-Volt 4 wire Motor Application

Wiring Diagram for
1PHE-4Wire used with 240V
4 Wire Motor

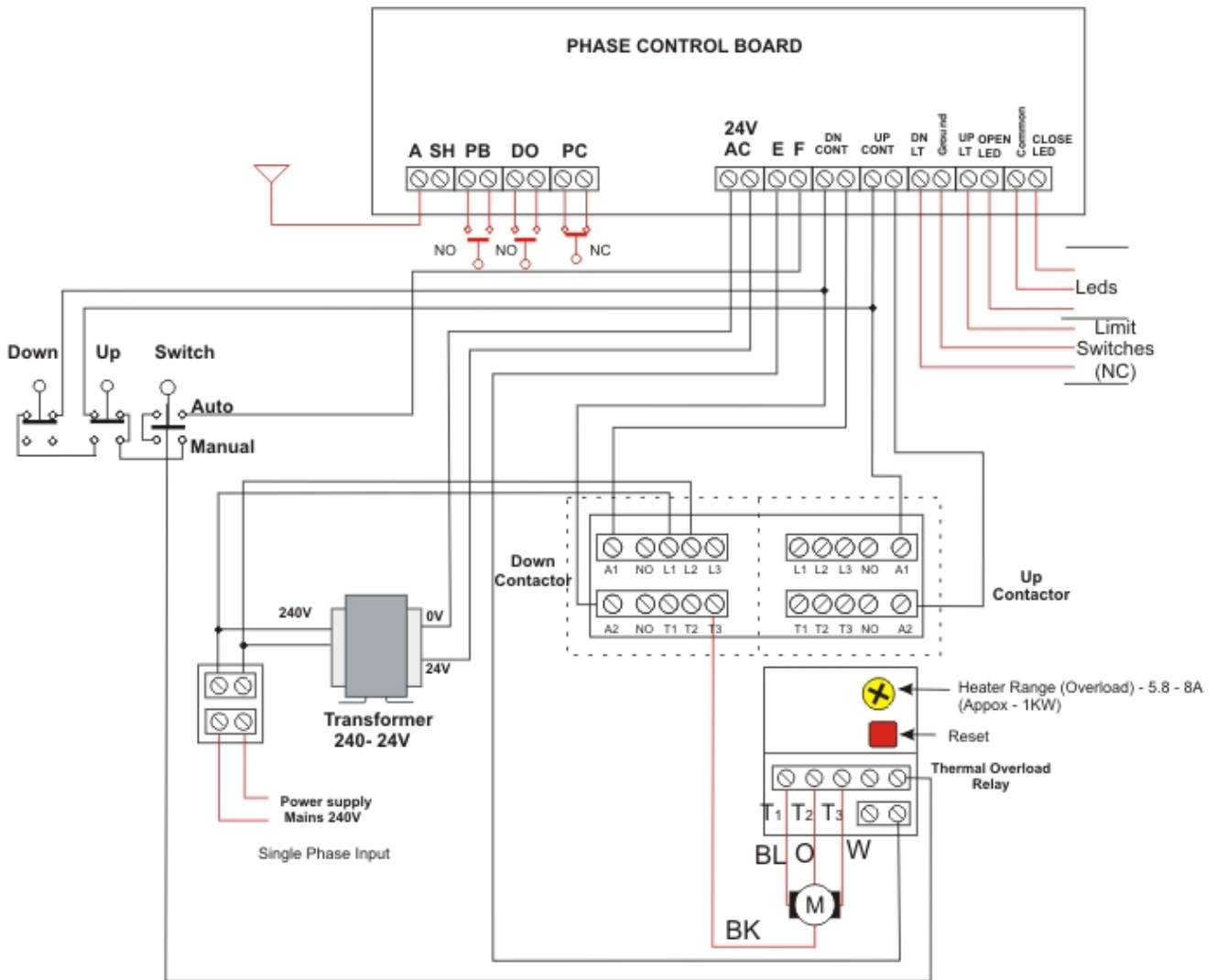

Connections in red will be done by the user

Manufactured by

Elsema Pty Ltd
3/10 Hume Rd, Smithfield
NSW 2164
Ph: 02 9609 4668
Fax: 02 9725 2663
Website: <http://www.elsema.com>

Distributed by

